



ANSI Catalogue

Our product range

Lined Pipes

Spacers

Flanged Elbows

Flanged Tees

Flanged Lateral Tees

Flanged Crosses

Instrument Tees

Reducers

Valves

Blind Flanges

Expansion Joints

Spectacle Blinds

Nozzle Liners / Dip Pipes

Hoses

Special Parts

Accessories

Technical Specifications

Innovation and quality. BAUM.



Headquarters in Birkenfeld

BAUM lined piping GmbH, located in Birkenfeld (Germany), manufactures the complete range of PTFE-lined piping components - according to both DIN and ANSI standards.

Over the course of the last 30 years, the family enterprise BAUM has developed into a stable, internationally successful company. With excellent products, global references and subsidiaries around the world, we are a strong and reliable partner.

What does BAUM offer to you?

First priority:

QUALITY

We offer long-term safety and security to chemical manufacturers:

- certification according DIN EN ISO 9001
- qualification according Pressure Equipment Directive (PED)
- FDA-conformity of the lining

Urgent solutions to challenges:

FLEXIBILITY

We react quickly to individual requirements:

- quick decisions and a motivated team
- state of the art technical production equipment, including internal steel fabrication

Individual piping systems:

INDIVIDUALITY

For some issues in plant manufacturing there are no standard solutions. We thrive to offer solutions to special or difficult applications. We are able to achieve this via:

- vertical integration of our production
- in-house construction
- independence from subcontractors

The BAUM-Team



Lined Pipes



Lined Pipes (Class 150)

Our pipes are lined, totally stainless, with paste-extruded PTFE and fully automatically tested. Depending on the nominal pipe size, we produce pipes up to a total length of 6 metres.



Lined Pipes (Class 150)

Materials:

- carbon steel
- stainless steel

Lining materials:

- PTFE (virgin or conductive)
- PP PP (up to nominal pipe size NPS 12")

Flanges

- fix-loose
- fix-fix
- loose-loose

Other pressure rating:

- Class 300

Special features:

- earthing stud/lug
- vent hole extension
- flange stopper

Optional extras:

- final painting
- non-destructive testing

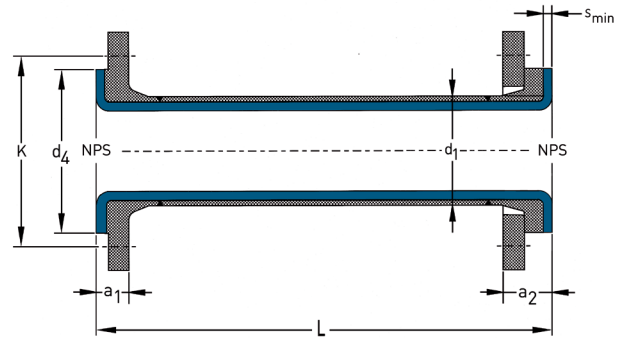

NPS	L (mm)		d ₁ (mm)	d ₄ (mm)	K (mm)	s _{min} (mm)	a ₁ (mm)	a ₂ (mm)	No. of bolts x thread (UNC)	Weights	
	min.	max.								Pipe (ca. kg/m)	Pair of flanges (ca. kg)
1/2"	70	6000	26.7	34.9	60.3	3.0	14.6	18.2	4 x 1/2"	2.1	0.8
3/4"	94	6000	26.7	42.9	69.9	3.0	16.2	19.7	4 x 1/2"	2.1	1.4
1"	98	6000	33.4	50.8	79.4	3.0	17.7	21.3	4 x 1/2"	3.0	2.0
1 1/4"	104	6000	42.2	63.5	88.9	3.0	19.3	22.9	4 x 1/2"	4.0	2.7
1 1/2"	109	6000	48.3	73.0	98.4	3.0	20.9	24.5	4 x 1/2"	4.8	3.5
2"	115	6000	60.3	92.1	120.7	3.0	22.5	26.6	4 x 5/8"	6.4	5.3
2 1/2"	126	6000	73.0	104.8	139.7	3.0	25.7	30.5	4 x 5/8"	9.8	8.4
3"	127	6000	88.9	127.0	152.4	3.0	27.3	32.4	4 x 5/8"	12.8	10.2
4"	137	6000	114.3	157.2	190.5	3.0	27.3	32.9	8 x 5/8"	18.1	14.3
5"	159	6000	141.3	185.7	215.9	4.0	28.3	34.5	8 x 3/4"	25.1	18.2
6"	163	6000	168.3	215.9	241.3	4.5	30.4	37.0	8 x 3/4"	32.8	22.6
8"	182	6000	219.1	269.9	298.5	5.0	34.0	41.8	8 x 3/4"	49.2	37.3
10"	188	4000	273.0	323.8	362.0	7.5	38.1	47.0	12 x 7/8"	72.8	50.7
12"	209	4000	323.8	381.0	431.8	5.0	37.2	47.1	12 x 7/8"	84.0	77.0
14"	249	3000	355.6	412.8	476.3	5.0	40.4	55.0	12 x 1"	92.5	101.2
16"	261	3000	406.4	469.9	539.8	5.0	42.0	56.6	16 x 1"	106.2	128.9
18"	280	2000	457.0	533.4	577.9	5.0	45.1	59.7	16 x 1 1/8"	119.8	144.6
20"	291	2000	508.0	584.2	635.0	5.0	48.3	62.9	20 x 1 1/8"	133.5	177.6

Nominal pipe sizes over NPS 20"
up to NPS 1000" on request.

NPS	Lining thickness		Possible vacuum		
	standard	thick-walled	23°C	150°C	200°C
1"	●	●	■	■	■
1 1/2"	●	●	■	■	■
2"	●	●	■	■	■
3"	●	●	■	■	■
4"	●	●	■	■	■
6"	●	●	■	■	■
8"	●	●	■	■	■
10"	●	●	■	■	■
10"	●	●	■	■	■

Vacuum resistance:

- = full vacuum
- ▨ = limited vacuum
- = no vacuum

Please refer to the next higher nominal pipe size if your nominal pipe size is not listed.

L = Total length

L_{min} = Minimum total length with flanges fix-loose

d₁ = Outer diameter of the pipe

d₄ = Raised face diameter

K = Bolt circle diameter

s_{min} = Minimum flare thickness

a₁ = Minimum length with fixed flange and s_{min}

a₂ = Minimum length with loose flange and s_{min}

Technical data valid for the pressure rating Class 150.

a₁ and a₂ depend on construction type and lining thickness.



Spacers



Spacers Form F (Class 150)

Flexible up to the last millimetre! For total lengths up to 25 mm we recommend Spacers Form F made of solid PTFE.

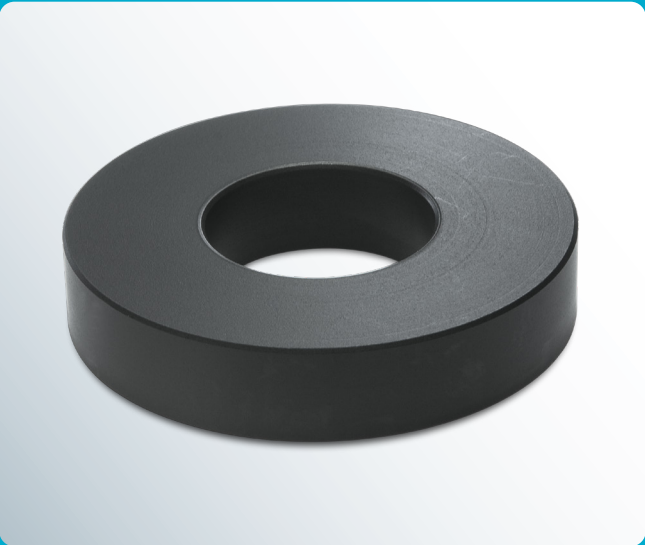
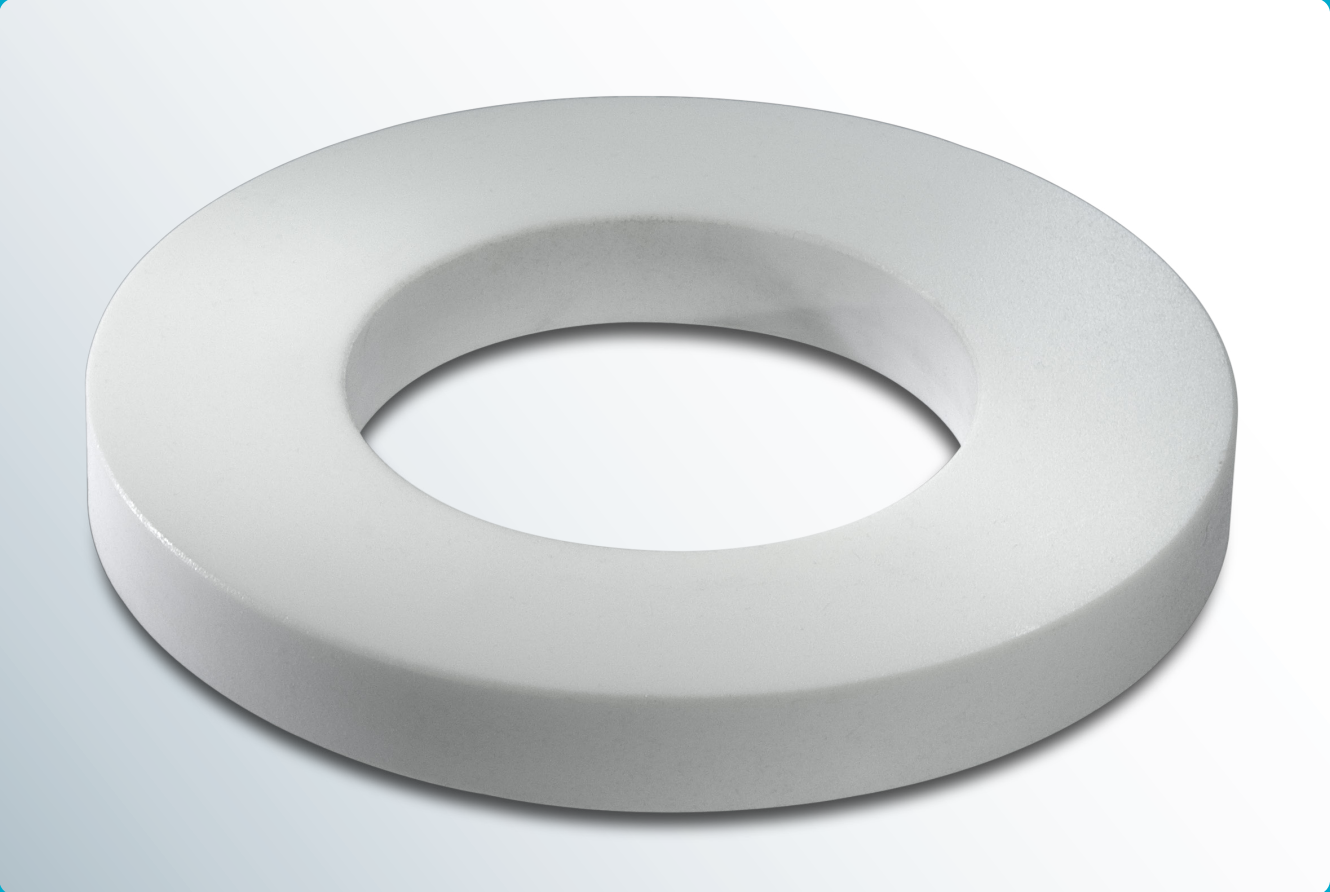

Spacers Form F (Class 150)

Materials:

- PTFE (virgin or conductive)
- PP (up to nominal pipe size NPS 12")

Other pressure rating:

- Class 300

Optional extras:

- reinforcement ring
- filled PTFE

Spacers Form F are also available as Inclined Spacers with various angles.

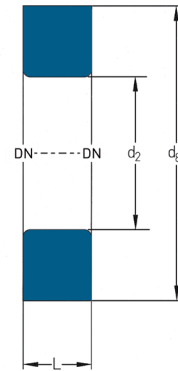

NPS	L (mm)		d ₂ ≈ (mm)	d ₈ (mm)	Weights (ca. g/mm)
	min.	max.			
1/2"	10	15	15	44	2.9
3/4"	10	20	15	54	4.5
1"	10	20	20	63	6.0
1 1/4"	10	20	29	73	7.6
1 1/2"	10	20	35	83	9.6
2"	10	20	45	101	13.8
2 1/2"	10	20	57	122	19.6
3"	10	20	70	133	21.6
4"	10	20	93	170	34.2
5"	10	20	119	194	39.6
6"	10	20	144	219	46.0
8"	10	20	191	273	64.2
10"	10	20	239	324	80.8
12"	10	20	290	405	135.0
14"	10	25	326	445	154.9
16"	10	25	372	510	205.5
18"	10	25	428	545	192.2
20"	10	25	470	600	234.9

Different nominal pipe sizes and total lengths on request.

L = Total length

d₂ = Inner diameter

d₈ = Outer diameter

Technical data valid for the pressure rating Class 150.

NPS	Lining thickness		Possible vacuum		
	standard	thick-walled	23°C	150°C	200°C
1"	●	●	■	■	■
1 1/2"	●	●	■	■	■
2"	●	●	■	■	■
3"	●	●	■	■	■
4"	●	●	■	■	■
6"	●	●	■	■	■
8"	●	●	■	■	■
10"	●	●	■	■	■
10"	●	●	■	■	■

Vacuum resistance:

■ = full vacuum

◐ = limited vacuum

○ = no vacuum

Please refer to the next higher nominal pipe size if your nominal pipe size is not listed.

Spacers Form G (Class 150)

For total lengths from 10 – 100 mm we reinforce the Spacers Form G with a resilient metal core.

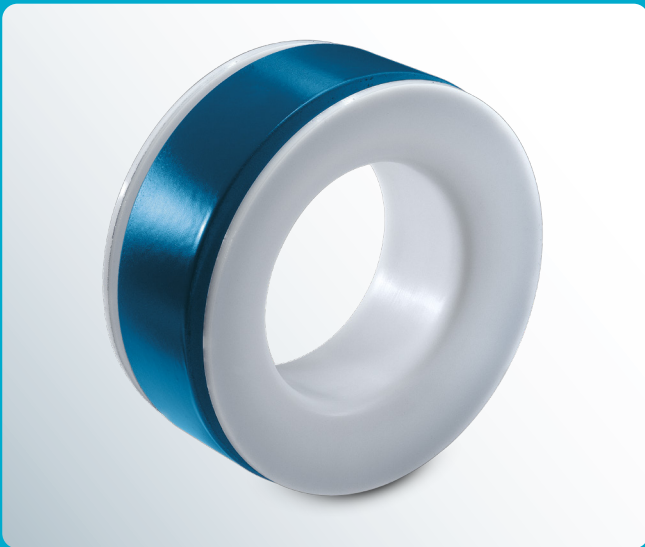

Spacers Form G (Class 150)

Materials:

- carbon steel
- stainless steel

Lining materials:

- PTFE (virgin or conductive)
- PP (up to nominal pipe size NPS 12")

Other pressure rating:

- Class 300

Special features:

- earthing stud/lug

Optional extras:

- final painting

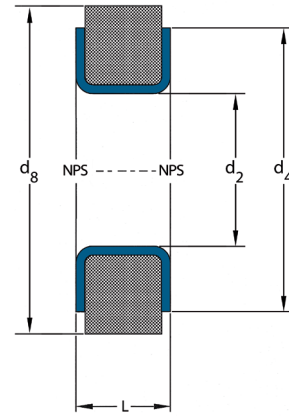

NPS	L (mm)		d ₂ ≈ (mm)	d ₄ (mm)	d ₈ (mm)	Weights at L _{max} (ca. kg/pc.)
	min.	max.				
1/2"	20	60	15	34.9	44	0.5
3/4"	20	60	15	42.9	54	0.9
1"	20	60	20	50.8	63	1.1
1 1/4"	20	60	29	63.5	73	1.4
1 1/2"	20	60	35	73.0	83	1.8
2"	20	60	45	92.1	101	2.6
2 1/2"	20	60	57	104.8	122	3.8
3"	20	70	70	127.0	133	4.9
4"	20	70	93	157.2	170	7.8
5"	30	70	119	185.7	194	8.5
6"	30	80	144	215.9	219	11.5
8"	30	80	191	269.9	273	15.8
10"	30	90	239	323.8	324	22.7
12"	30	90	290	381.0	405	38.3
14"	30	90	326	412.8	445	44.0
16"	45	90	372	469.9	510	58.7
18"	50	100	428	533.4	545	58.1
20"	50	100	470	584.2	600	75.4

Different nominal pipe sizes and total lengths on request.

L = Total length

d₂ = Inner diameter

d₄ = Raised face diameter

d₈ = Outer diameter

Technical data valid for the pressure rating Class 150.

NPS	Lining thickness		Possible vacuum		
	standard	thick-walled	23°C	150°C	200°C
1"	●	●	■	■	■
1 1/2"	●	●	■	■	■
2"	●	●	■	■	■
3"	●	●	■	■	■
4"	●	●	■	■	■
6"	●	●	■	■	■
8"	●	●	■	■	■
10"	●	●	■	■	■
12"	●	●	■	■	■

Vacuum resistance:

■ = full vacuum

▤ = limited vacuum

○ = no vacuum

Please refer to the next higher nominal pipe size if your nominal pipe size is not listed.

Spacers Form H (Class 150)

Spacers Form H with a total length up to 250 mm consist of a pressure-resistant, but lightweight metal core with interior lining.

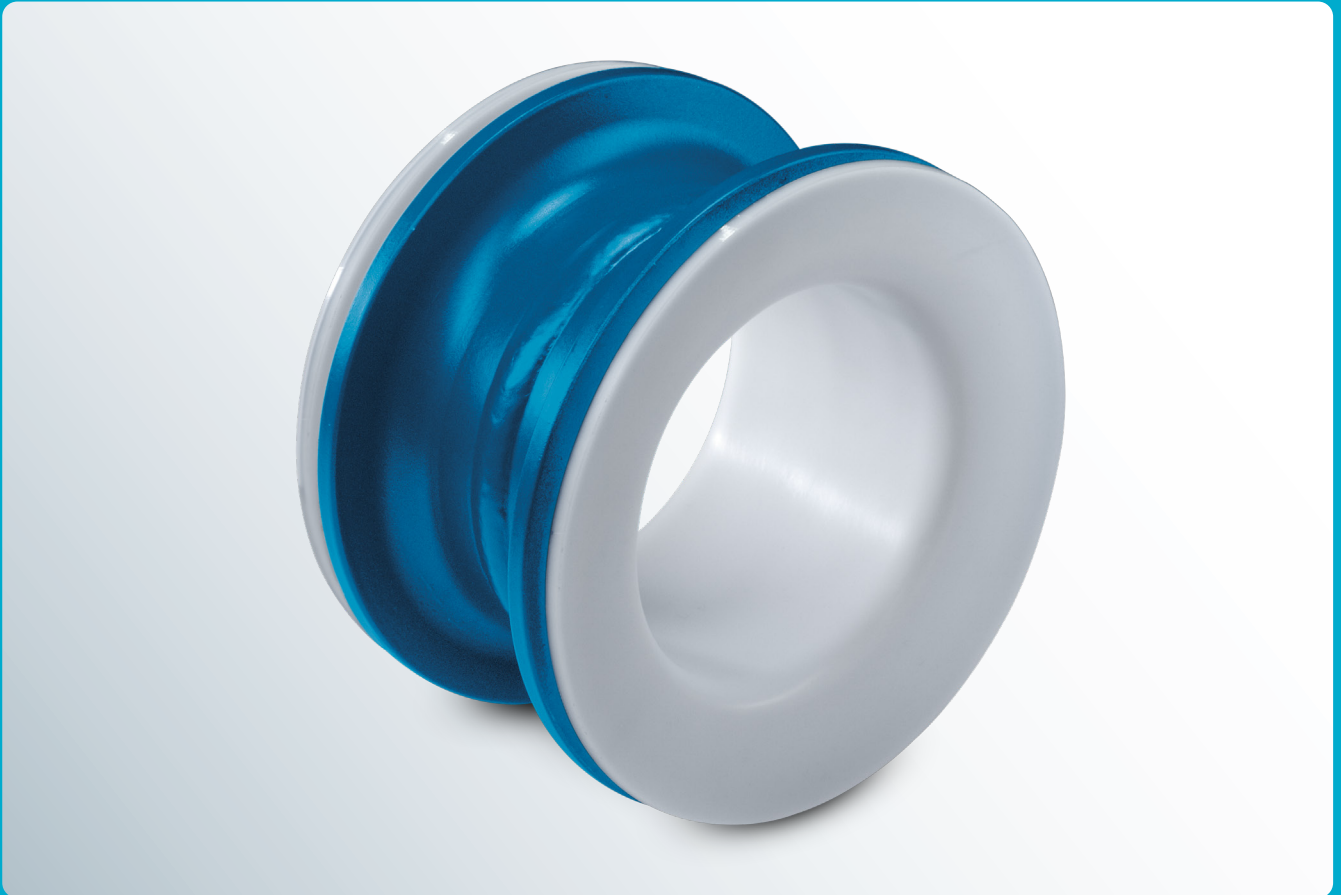

Spacers Form H (Class 150)

Materials:

- carbon steel
- stainless steel

Lining materials:

- PTFE (virgin or conductive)
- PP (up to nominal pipe size NPS 12")

Other pressure rating:

- Class 300

Special features:

- earthing stud/lug
- vent hole extension

Optional extras:

- final painting
- non-destructive testing

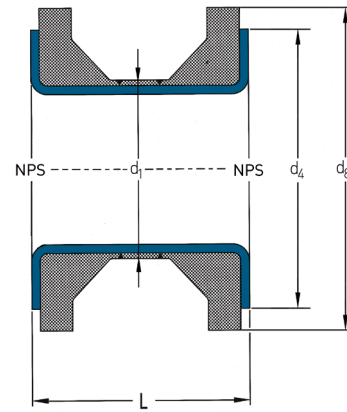

NPS	L (mm)		d ₁ (mm)	d ₄ (mm)	d ₈ (mm)	Weights at L _{max} (ca. kg/pc.)
	min.	max.				
1/2"	60	100	26.7	34.9	39.0	0.3
3/4"	60	100	26.7	42.9	47.0	0.3
1"	60	100	33.4	50.8	54.0	0.4
1 1/4"	60	100	42.2	63.5	67.0	0.6
1 1/2"	60	100	48.3	73.0	77.0	0.7
2"	60	100	60.3	92.1	97.0	1.0
2 1/2"	60	100	73.0	104.8	108.0	1.4
3"	70	125	88.9	127.0	131.0	2.3
4"	70	125	114.3	157.2	161.0	3.2
5"	70	150	141.3	185.7	190.0	5.2
6"	80	150	168.3	215.9	219.0	6.6
8"	80	200	219.1	269.9	270.0	12.4
10"	80	200	273.0	323.8	324.0	17.0
12"	80	200	323.8	381.0	381.0	21.7
14"	80	250	355.6	412.8	413.0	31.4
16"	90	250	406.4	469.9	470.0	37.6
18"	100	250	457.0	533.4	533.4	44.8
20"	100	250	508.0	584.2	586.0	49.2

Different nominal pipe sizes and total lengths on request.

L = Total length
d₁ = Outer diameter of the steel pipe
d₄ = Raised face diameter
d₈ = Outer diameter
Technical data valid for the pressure rating Class 150.

NPS	Lining thickness		Possible vacuum		
	standard	thick-walled	23°C	150°C	200°C
1"	●	●	■	■	■
1 1/2"	●	●	■	■	■
2"	●	●	■	■	■
3"	●	●	■	■	■
4"	●	●	■	■	■
6"	●	●	■	■	■
8"	●	●	■	■	■
10"	●	●	■	■	■
12"	●	●	■	■	■

Vacuum resistance:

- = full vacuum
- ▤ = limited vacuum
- = no vacuum

Please refer to the next higher nominal pipe size if your nominal pipe size is not listed.

Inclined Spacers (Class 150)

Flexible in every situation! The Inclined Spacers can be delivered in any angle, tapered on one side only or on both sides.

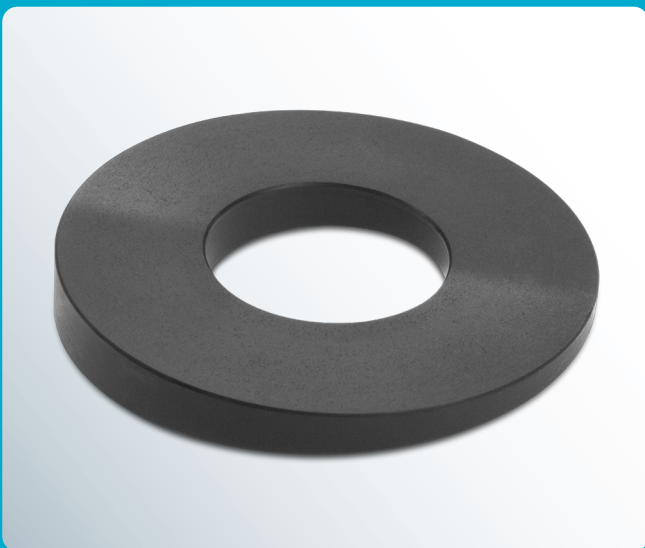
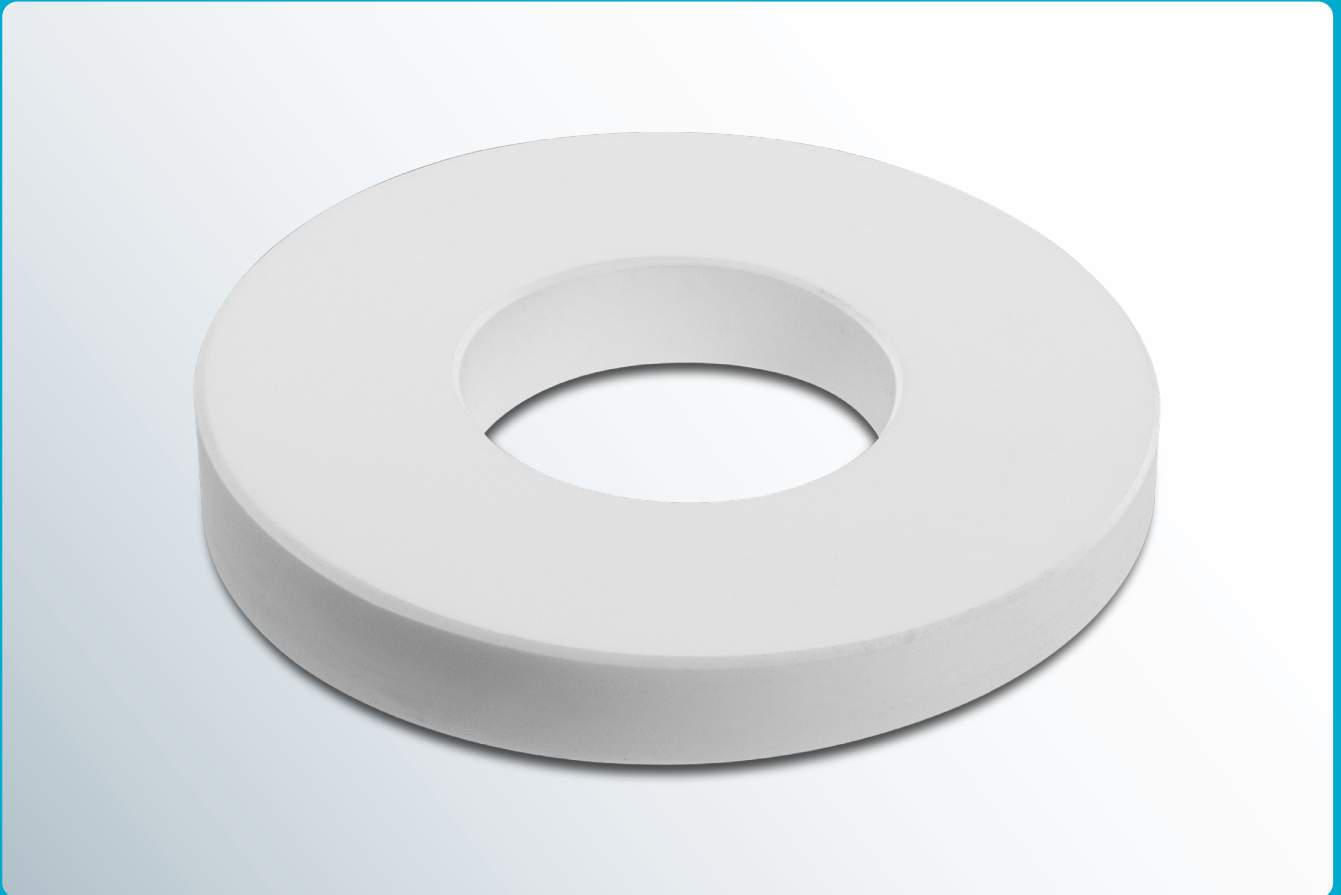

Inclined Spacers (Class 150)

Material:

- PTFE (virgin or conductive)

Other pressure rating:

- Class 300

The standard angle for Inclined Spacer is 3°, other angles on request.

NPS	L (mm)	d ₂ ≈ (mm)	d ₈ (mm)	Weights (ca. kg/pc.)
1"	15	20	63	0.1
1¼"	15	29	73	0.1
1½"	15	35	83	0.1
2"	20	45	101	0.3
2½"	20	57	122	0.4
3"	20	70	133	0.4
4"	25	93	170	0.9
5"	25	119	194	1.0
6"	35	144	219	1.6
8"	35	191	273	2.2

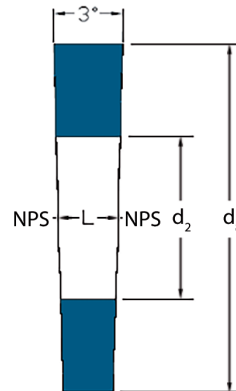

Different nominal pipe sizes and total lengths on request.

L = Total length

d₂ = Inner diameter

d₈ = Outer diameter

Technical data valid for the pressure rating Class 150.

NPS	Lining thickness		Possible vacuum		
	standard	thick-walled	23°C	150°C	200°C
1"	●	●	■	■	■
1½"	●	●	■	■	■
2"	●	●	■	■	■
3"	●	●	■	■	■
4"	●	●	■	■	■
6"	●	●	■	■	■
8"	●	●	■	■	■

Vacuum resistance:

■ = full vacuum

◐ = limited vacuum

○ = no vacuum

Please refer to the next higher nominal pipe size if your nominal pipe size is not listed.



Flanged Elbows

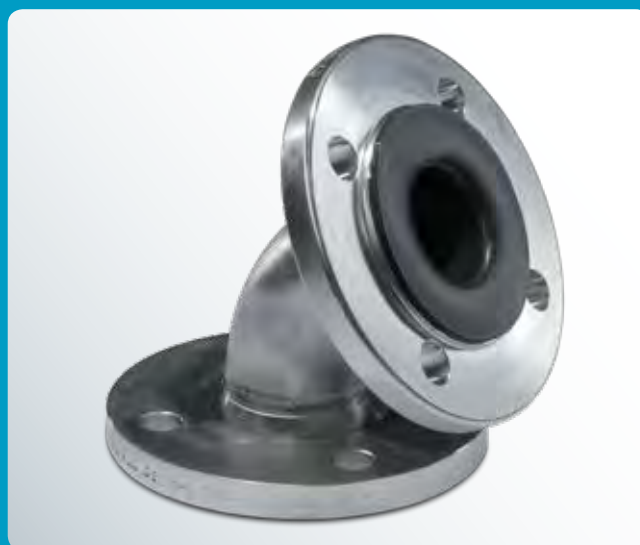

Flanged Elbows 30° / 60° (Class 150)

The BAUM manufacturing technology with paste-extruded PTFE liner assures an optimum flow and an exact fitting of the liner in the elbow segment.

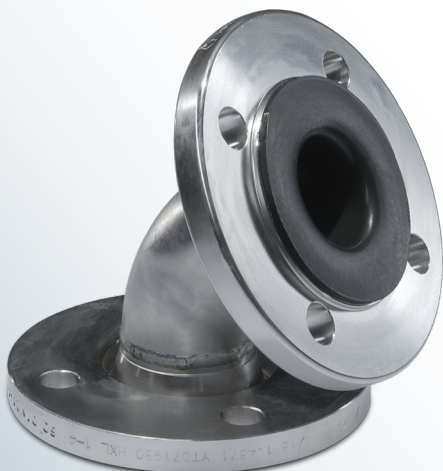
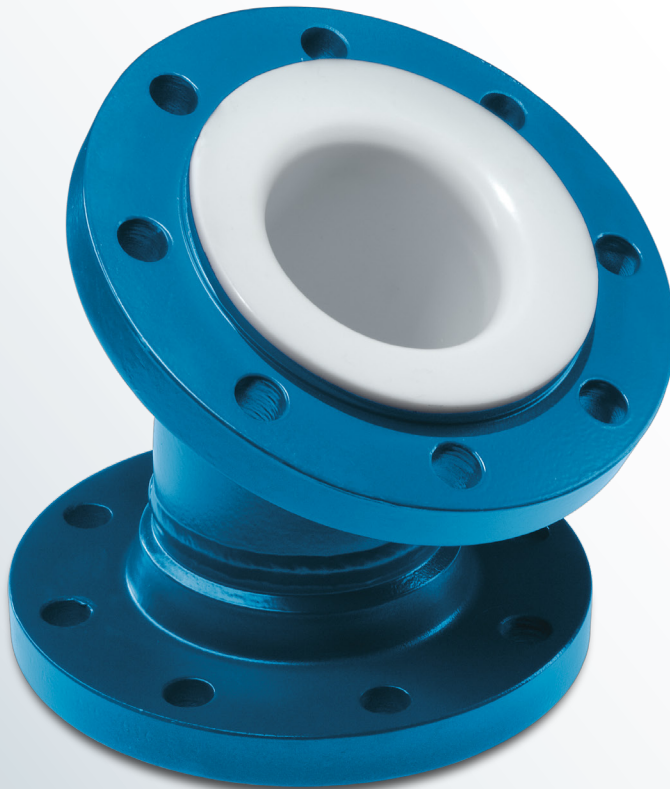

Flanged Elbows 30° / 60° (Class 150)

Materials:

- carbon steel
- stainless steel

Lining materials:

- PTFE (virgin or conductive)
- PP (up to nominal pipe size NPS 12")

Flanges:

- fix-loose
- fix-fix
- loose-loose

Other pressure rating:

- Class 300

Special features:

- earthing stud/lug
- vent hole extension
- flange stopper

Optional extras:

- final painting
- non-destructive testing

30°

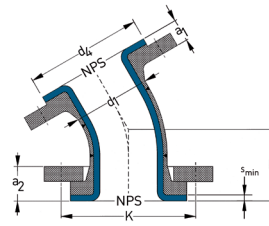

60°

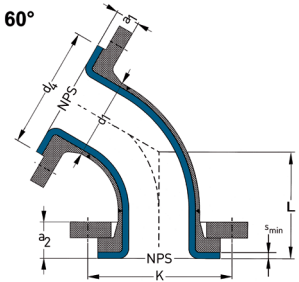

NPS	L (mm)		d ₁ (mm)	d ₄ (mm)	K (mm)	s _{min} (mm)	a ₁ (mm)	a ₂ (mm)	No. of bolts x thread (UNC)	Weights	
	30°	60°								30° (ca. kg/pc.)	60° (ca. kg/pc.)
1/2"	45	60	26.7	34.9	60.3	3.0	14.6	22.2	4 x 1/2"	1.1	1.1
3/4"	45	60	26.7	42.9	69.9	3.0	16.2	23.7	4 x 1/2"	1.7	1.8
1"	45	60	33.4	50.8	79.4	3.0	17.7	25.3	4 x 1/2"	2.3	2.5
1 1/4"	51	65	42.2	63.5	88.9	3.0	19.3	26.9	4 x 1/2"	3.1	3.4
1 1/2"	57	70	48.3	73.0	98.4	4.0	21.9	29.5	4 x 1/2"	3.8	4.0
2"	64	80	60.3	92.1	120.7	3.0	22.5	30.1	4 x 3/8"	5.7	6.0
2 1/2"	76	96	73.0	104.8	139.7	4.0	26.7	34.3	4 x 5/8"	9.0	9.5
3"	76	96	88.9	127.0	152.4	4.0	28.3	35.9	4 x 5/8"	11.0	11.7
4"	102	122	114.3	157.2	190.5	4.5	28.8	36.4	8 x 5/8"	15.8	17.0
5"	114	130	141.3	185.7	215.9	5.0	29.3	36.9	8 x 3/4"	20.5	22.5
6"	127	135	168.3	215.9	241.3	5.0	30.9	38.4	8 x 3/4"	26.0	29.1
8"	140	155	219.1	269.9	298.5	6.0	35.0	42.6	8 x 3/4"	43.7	49.8
10"	165	185	273.0	323.8	362.0	6.0	36.6	46.2	12 x 7/8"	61.5	71.9
12"	190	215	323.8	381.0	431.8	5.0	37.2	46.8	12 x 7/8"	92.7	108.1
14"	190	245	355.6	412.8	476.3	6.0	41.4	51.0	12 x 1"	121.4	141.2
16"	203	275	406.4	469.9	539.8	7.0	44.0	58.6	16 x 1"	156.5	183.5
18"	240	302	457.0	533.4	577.9	5.0	45.1	59.7	16 x 1 1/8"	177.6	210.1
20"	225	332	508.0	584.2	635.0	5.0	48.3	62.9	20 x 1 1/8"	218.5	258.6

NPS	Lining thickness		Possible vacuum		
	standard	thick-walled	23°C	150°C	200°C
1"	●	●	■	■	○
1 1/2"	●	●	■	■	○
2"	●	●	■	■	○
3"	●	●	■	■	○
4"	●	●	■	■	○
6"	●	●	■	■	○
8"	●	●	■	■	○
10"	●	●	■	■	○
12"	●	●	■	■	○

Vacuum resistance:

- = full vacuum
- (lighter) = limited vacuum
- = no vacuum

Please refer to the next higher nominal pipe size if your nominal pipe size is not listed.

Nominal pipe sizes over NPS 20" up to NPS 1000" on request.

- L = Total length
 - d₁ = Outer diameter of the elbow
 - d₄ = Raised face diameter
 - K = Bolt circle diameter
 - s_{min} = Minimum flare thickness
 - a₁ = Minimum length with fixed flange and s_{min}
 - a₂ = Minimum length with loose flange and s_{min}
- Technical data valid for the pressure rating Class 150.
a₁ and a₂ depend on construction type and lining thickness.

Flanged Elbows 45° / 90° (Class 150)

The BAUM manufacturing technology with paste-extruded PTFE liner assures an optimum flow and an exact fitting of the liner in the elbow segment.

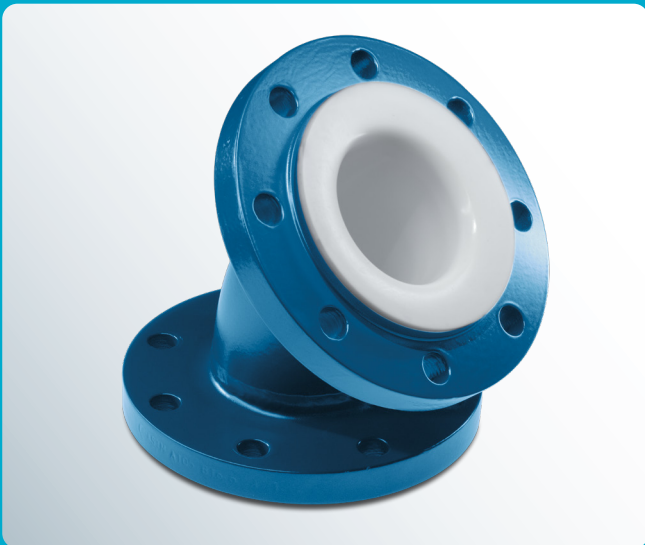
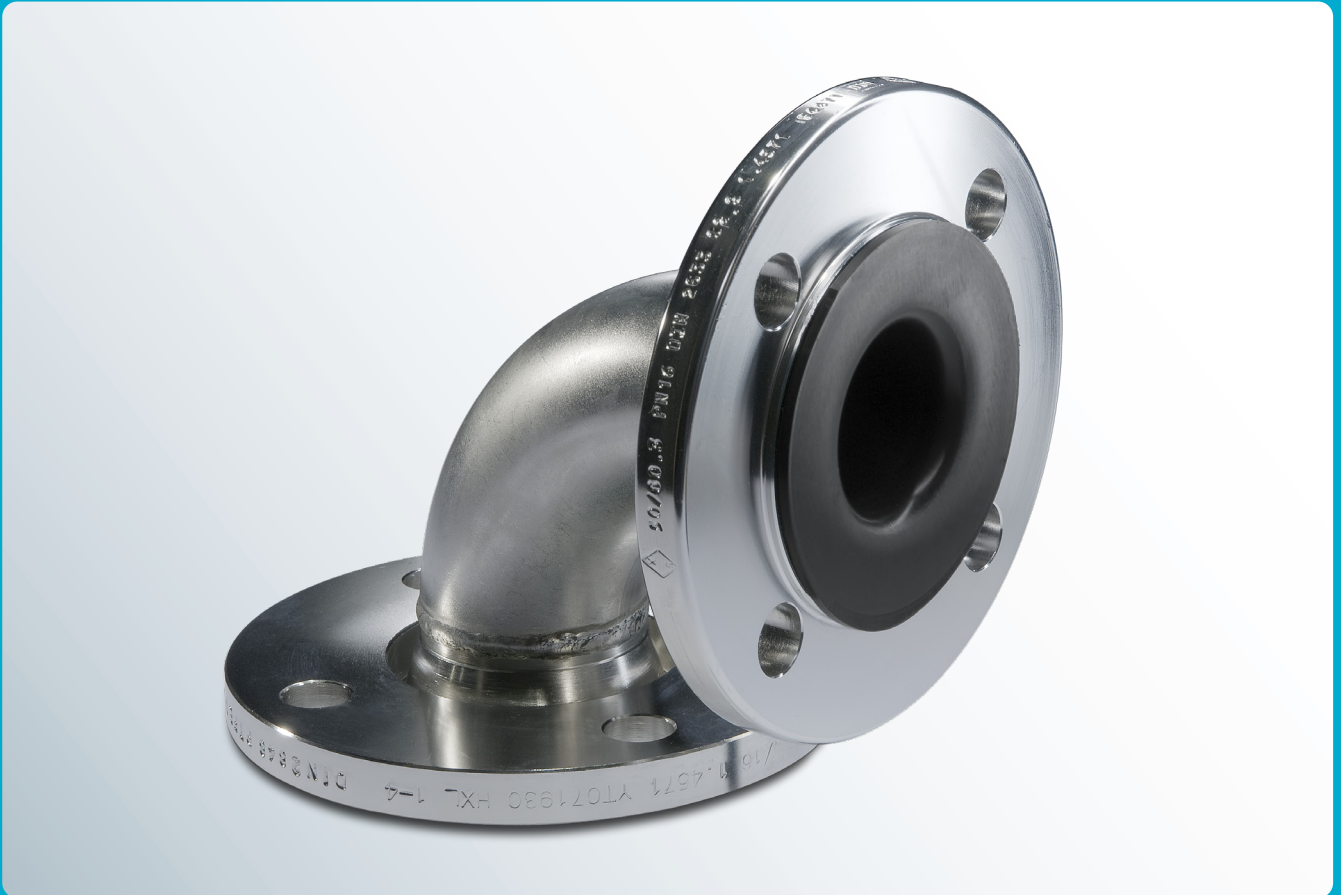

Flanged Elbows 45° / 90° (Class 150)

Materials:

- carbon steel
- stainless steel

Lining materials:

- PTFE (virgin or conductive)
- PP (up to nominal pipe size NPS 12")

Flanges:

- fix-loose
- fix-fix
- loose-loose

Other pressure rating:

- Class 300

Special features:

- earthing stud/lug
- vent hole extension
- flange stopper

Optional extras:

- final painting
- non-destructive testing

45°

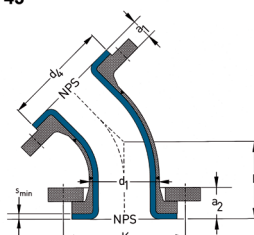

90°

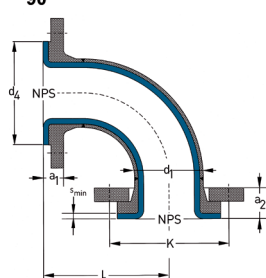

NPS	L (mm)		d ₁ (mm)	d ₄ (mm)	K (mm)	s _{min} (mm)	a ₁ (mm)	a ₂ (mm)	No. of bolts x thread (UNC)	Weights		
	45°	90°								45° (ca. kg/pc.)	90° SR (ca. kg/pc.)	
		SR										LR
1/2"	44	65		26.7	34.9	60.3	3.0	14.6	22.2	4 x 1/2"	1.1	1.1
3/4"	44	75		26.7	42.9	69.9	3.0	16.2	23.7	4 x 1/2"	1.7	1.8
1"	44	89	127	33.4	50.8	79.4	3.0	17.7	25.3	4 x 1/2"	2.4	2.6
1 1/4"	51	95	140	42.2	63.5	88.9	3.0	19.3	26.9	4 x 1/2"	3.2	3.5
1 1/2"	57	102	152	48.3	73.0	98.4	4.0	21.9	29.5	4 x 1/2"	3.9	4.0
2"	64	114	165	60.3	92.1	120.7	3.0	22.5	30.1	4 x 5/8"	5.8	6.2
2 1/2"	76	127	178	73.0	104.8	139.7	4.0	26.7	34.3	4 x 5/8"	9.3	10.0
3"	76	140	197	88.9	127.0	152.4	4.0	28.3	35.9	4 x 5/8"	11.4	12.3
4"	102	165	229	114.3	157.2	190.5	4.5	28.8	36.4	8 x 5/8"	16.4	18.1
5"	114	190	260	141.3	185.7	215.9	5.0	29.3	36.9	8 x 3/4"	21.5	24.3
6"	127	203	292	168.3	215.9	241.3	5.0	30.9	38.4	8 x 3/4"	27.5	31.7
8"	140	229	356	219.1	269.9	298.5	6.0	35.0	42.6	8 x 3/4"	46.7	55.0
10"	165	279	419	273.0	323.8	362.0	6.0	36.6	46.2	12 x 7/8"	66.7	80.7
12"	190	305	483	323.8	381.0	431.8	5.0	37.2	46.8	12 x 7/8"	100.4	150.9
14"	190	356	546	355.6	412.8	476.3	6.0	41.4	51.0	12 x 1"	131.3	202.4
16"	203	381	610	406.4	469.9	539.8	7.0	44.0	58.6	16 x 1"	170.0	267.5
18"	216	419	673	457.0	533.4	577.9	5.0	45.1	59.7	16 x 1 1/8"	193.8	312.5
20"	241	457	737	508.0	584.2	635.0	5.0	48.3	62.9	20 x 1 1/8"	238.6	469.0

NPS	Lining thickness		Possible vacuum		
	standard	thick-walled	23°C	150°C	200°C
1"	●	●	☐	☐	☐
1 1/2"	●	●	☐	☐	☐
2"	●	●	☐	☐	☐
3"	●	●	☐	☐	☐
4"	●	●	☐	☐	☐
6"	●	●	☐	☐	☐
8"	●	●	☐	☐	☐
10"	●	●	☐	☐	☐
12"	●	●	☐	☐	☐

Vacuum resistance:

- ☐ = full vacuum
- ☐ = limited vacuum
- ☐ = no vacuum

Please refer to the next higher nominal pipe size if your nominal pipe size is not listed.

Nominal pipe sizes over NPS 20" up to NPS 1000" on request.

- L = Total length
 - d₁ = Outer diameter of the elbow
 - d₄ = Raised face diameter
 - K = Bolt circle diameter
 - s_{min} = Minimum flare thickness
 - a₁ = Minimum length with fixed flange and s_{min}
 - a₂ = Minimum length with loose flange and s_{min}
- Technical data valid for the pressure rating Class 150.
a₁ and a₂ depend on construction type and lining thickness.

Types of Flanged Elbows 90°:

- from nominal pipe size NPS 12" as two-part component
- from nominal pipe size NPS 20" as three-part component



Flanged Tees



Flanged Tees (Class 150)

The one-piece design with PFA or PP lining assures a perfect flow in the base body and at the outlet. The manufacturing of our one-piece Flanged Tees is done by injection moulding. For Flanged Tees with nominal pipe

sizes larger than NPS, 4", we rely on our approved paste liner. Both manufacturing technologies assure a special smooth and easy-to-clean surface.



Flanged Tees (Class 150)

Materials:

- carbon steel
- stainless steel

Lining materials:

- up to nominal pipe size NPS₁ 4" (one-piece): PFA
- up to nominal pipe size NPS₁ 4" (one-piece): PP
- from nominal pipe size NPS₁ 5" (one-piece): on request
- from nominal pipe size NPS₁ 5" (two-piece): PTFE (virgin or conductive)

Flanges (reading order A-B-C):

- combinations of fixed flanges
- combinations of loose flanges
- combinations of fixed and loose flanges

Other pressure rating:

- Class 300

Special features:

- earthing stud/lug
- vent hole extension
- flange stopper

Optional extras:

- final painting
- non-destructive testing

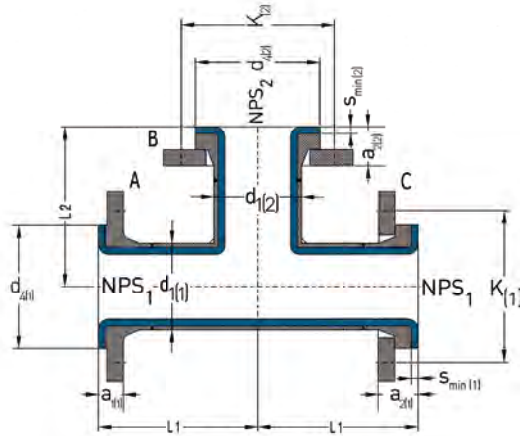

one-piece

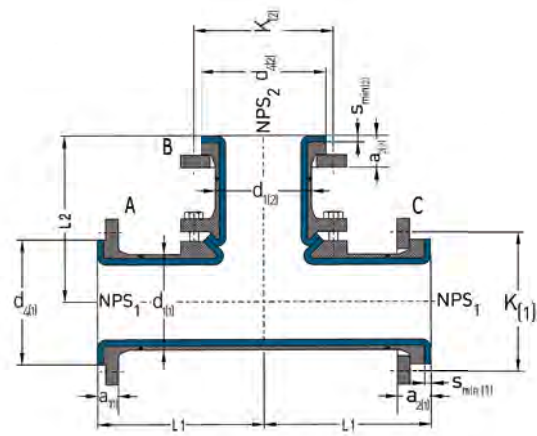

two-piece

NPS ₁	NPS ₂	L ₁ (mm)	L ₂ (mm)	d ₁₍₁₎ (mm)	d ₄₍₁₎ (mm)	K ₁₍₁₎ (mm)	s _{min(1)} (mm)	a ₁₍₁₎ (mm)	a ₂₍₁₎ (mm)	d ₁₍₂₎ (mm)	d ₄₍₂₎ (mm)	K ₁₍₂₎ (mm)	s _{min(2)} (mm)	a ₁₍₂₎ (mm)	a ₂₍₂₎ (mm)	No. of bolts x thread (UNC)		Wt. (ca. kg/pc.)
																NPS ₁	NPS ₂	
1/2"	1/2"	65	65	26.7	34.9	60.3	4.0	15.6	19.2	26.7	34.9	60.3	4.0	15.6	19.2	4 x 1/2"	4 x 1/2"	1.5
3/4"	1/2"	75	75	26.7	42.9	69.9	4.0	17.2	20.7	26.7	34.9	60.3	4.0	15.6	19.2	4 x 1/2"	4 x 1/2"	2.3
3/4"	3/4"	75	75	26.7	42.9	69.9	4.0	17.2	20.7	26.7	42.9	69.9	4.0	17.2	20.7	4 x 1/2"	4 x 1/2"	2.7
1"	1/2"	89	89	33.4	50.8	79.4	4.0	18.7	22.3	26.7	34.9	60.3	4.0	15.6	19.2	4 x 1/2"	4 x 1/2"	3.2
1"	3/4"	89	89	33.4	50.8	79.4	4.0	18.7	22.3	26.7	42.9	69.9	4.0	17.2	20.7	4 x 1/2"	4 x 1/2"	3.5
1"	1"	89	89	33.4	50.8	79.4	4.0	18.7	22.3	33.4	50.8	79.4	4.0	18.7	22.3	4 x 1/2"	4 x 1/2"	3.9
1 1/4"	1/2"	95	95	42.2	63.5	88.9	4.0	20.3	23.9	26.7	34.9	60.3	4.0	15.6	19.2	4 x 1/2"	4 x 1/2"	4.1
1 1/4"	3/4"	95	95	42.2	63.5	88.9	4.0	20.3	23.9	26.7	42.9	69.9	4.0	17.2	20.7	4 x 1/2"	4 x 1/2"	4.4
1 1/4"	1"	95	95	42.2	63.5	88.9	4.0	20.3	23.9	33.4	50.8	79.4	4.0	18.7	22.3	4 x 1/2"	4 x 1/2"	4.8
1 1/4"	1 1/4"	95	95	42.2	63.5	88.9	4.0	20.3	23.9	42.2	63.5	88.9	4.0	20.3	23.9	4 x 1/2"	4 x 1/2"	5.3
1 1/2"	3/4"	102	102	48.3	73.0	98.4	4.0	21.9	25.5	26.7	42.9	69.9	4.0	17.2	20.7	4 x 1/2"	4 x 1/2"	4.7
1 1/2"	1"	102	102	48.3	73.0	98.4	4.0	21.9	25.5	33.4	50.8	79.4	4.0	18.7	22.3	4 x 1/2"	4 x 1/2"	5.0
1 1/2"	1 1/4"	102	102	48.3	73.0	98.4	4.0	21.9	25.5	42.2	63.5	88.9	4.0	20.3	23.9	4 x 1/2"	4 x 1/2"	5.4
1 1/2"	1 1/2"	102	102	48.3	73.0	98.4	4.0	21.9	25.5	48.3	73.0	98.4	4.0	21.9	25.5	4 x 1/2"	4 x 1/2"	5.8
2"	1"	114	114	60.3	92.1	120.7	4.0	23.5	27.6	33.4	50.8	79.4	4.0	18.7	22.3	4 x 5/8"	4 x 1/2"	7.1
2"	1 1/4"	114	114	60.3	92.1	120.7	4.0	23.5	27.6	42.2	63.5	88.9	4.0	20.3	23.9	4 x 5/8"	4 x 1/2"	7.5
2"	1 1/2"	114	114	60.3	92.1	120.7	4.0	23.5	27.6	48.3	73.0	98.4	4.0	21.9	25.5	4 x 5/8"	4 x 1/2"	7.9
2"	2"	114	114	60.3	92.1	120.7	4.0	23.5	27.6	60.3	92.1	120.7	4.0	23.5	27.6	4 x 5/8"	4 x 5/8"	8.9

continued on the next page

Flanged Tees (Class 150)

NPS ₁	NPS ₂	L ₁ (mm)	L ₂ (mm)	d ₁₍₁₎ (mm)	d ₄₍₁₎ (mm)	K ₁₍₁₎ (mm)	s _{min(1)} (mm)	a ₁₍₁₎ (mm)	a ₂₍₁₎ (mm)	d ₁₍₂₎ (mm)	d ₄₍₂₎ (mm)	K ₁₍₂₎ (mm)	s _{min(2)} (mm)	a ₁₍₂₎ (mm)	a ₂₍₂₎ (mm)	No. of bolts x thread [UNC]		Wt. (ca. kg/pc.)
																NPS ₁	NPS ₂	
2½"	1"	127	127	73.0	104.8	139.7	4.0	26.7	31.5	33.4	50.8	79.4	4.0	18.7	22.3	4 x 5/8"	4 x 1/2"	10.7
2½"	1¼"	127	127	73.0	104.8	139.7	4.0	26.7	31.5	42.2	63.5	88.9	4.0	20.3	23.9	4 x 5/8"	4 x 1/2"	11.2
2½"	1½"	127	127	73.0	104.8	139.7	4.0	26.7	31.5	48.3	73.0	98.4	4.0	21.9	25.5	4 x 5/8"	4 x 1/2"	11.6
2½"	2"	127	127	73.0	104.8	139.7	4.0	26.7	31.5	60.3	92.1	120.7	4.0	23.5	27.6	4 x 5/8"	4 x 5/8"	12.6
2½"	2½"	127	127	73.0	104.8	139.7	4.0	26.7	31.5	73.0	104.8	139.7	4.0	26.7	31.5	4 x 5/8"	4 x 5/8"	14.3
3"	1"	140	140	88.9	127.0	152.4	4.0	28.3	33.4	33.4	50.8	79.4	4.0	18.7	22.3	4 x 5/8"	4 x 1/2"	13.2
3"	1½"	140	140	88.9	127.0	152.4	4.0	28.3	33.4	48.3	73.0	98.4	4.0	21.9	25.5	4 x 5/8"	4 x 1/2"	14.1
3"	2"	140	140	88.9	127.0	152.4	4.0	28.3	33.4	60.3	92.1	120.7	4.0	23.5	27.6	4 x 5/8"	4 x 5/8"	15.1
3"	2½"	140	140	88.9	127.0	152.4	4.0	28.3	33.4	73.0	104.8	139.7	4.0	26.7	31.5	4 x 5/8"	4 x 5/8"	16.9
3"	3"	140	140	88.9	127.0	152.4	4.0	28.3	33.4	88.9	127.0	152.4	4.0	28.3	33.4	4 x 5/8"	4 x 5/8"	18.0
4"	1"	165	165	114.3	157.2	190.5	4.0	28.3	33.9	33.4	50.8	79.4	4.0	18.7	22.3	8 x 5/8"	4 x 1/2"	18.8
4"	2"	165	165	114.3	157.2	190.5	4.0	28.3	33.9	60.3	92.1	120.7	4.0	23.5	27.6	8 x 5/8"	4 x 5/8"	20.8
4"	2½"	165	165	114.3	157.2	190.5	4.0	28.3	33.9	73.0	104.8	139.7	4.0	26.7	31.5	8 x 5/8"	4 x 5/8"	22.6
4"	3"	165	165	114.3	157.2	190.5	4.0	28.3	33.9	88.9	127.0	152.4	4.0	28.3	33.4	8 x 5/8"	4 x 5/8"	23.8
4"	4"	165	165	114.3	157.2	190.5	4.0	28.3	33.9	114.3	157.2	190.5	4.0	28.3	33.9	8 x 5/8"	8 x 5/8"	26.3
5"	2½"	190	190	141.3	185.7	215.9	5.0	29.3	35.5	73.0	104.8	139.7	3.0	25.7	30.5	8 x 3/4"	4 x 5/8"	43.2
5"	3"	190	190	141.3	185.7	215.9	5.0	29.3	35.5	88.9	127.0	152.4	3.0	27.3	32.4	8 x 3/4"	4 x 5/8"	46.3
5"	4"	190	190	141.3	185.7	215.9	5.0	29.3	35.5	114.3	157.2	190.5	3.0	27.3	32.9	8 x 3/4"	8 x 5/8"	52.1
5"	5"	190	190	141.3	185.7	215.9	5.0	29.3	35.5	141.3	185.7	215.9	4.0	28.3	34.5	8 x 3/4"	8 x 3/4"	58.6
6"	3"	203	203	168.3	215.9	241.3	7.0	32.9	39.5	88.9	127.0	152.4	3.0	27.3	32.4	8 x 3/4"	4 x 5/8"	53.1
6"	4"	203	203	168.3	215.9	241.3	7.0	32.9	39.5	114.3	157.2	190.5	3.0	27.3	32.9	8 x 3/4"	8 x 5/8"	59.0
6"	5"	203	203	168.3	215.9	241.3	7.0	32.9	39.5	141.3	185.7	215.9	4.0	28.3	34.5	8 x 3/4"	8 x 3/4"	65.6
6"	6"	203	203	168.3	215.9	241.3	7.0	32.9	39.5	168.3	215.9	241.3	4.5	30.4	37.0	8 x 3/4"	8 x 3/4"	77.3
8"	4"	229	229	219.1	269.9	298.5	6.0	35.0	42.8	114.3	157.2	190.5	3.0	27.3	32.9	8 x 3/4"	8 x 5/8"	79.2
8"	5"	229	229	219.1	269.9	298.5	6.0	35.0	42.8	141.3	185.7	215.9	4.0	28.3	34.5	8 x 3/4"	8 x 3/4"	86.0
8"	6"	229	229	219.1	269.9	298.5	6.0	35.0	42.8	168.3	215.9	241.3	4.5	30.4	37.0	8 x 3/4"	8 x 3/4"	97.9
8"	8"	229	229	219.1	269.9	298.5	6.0	35.0	42.8	219.1	269.9	298.5	5.0	34.0	41.8	8 x 3/4"	8 x 3/4"	115.4
10"	5"	279	279	273.0	323.8	362.0	7.5	38.1	47.0	141.3	185.7	215.9	4.0	28.3	34.5	12 x 7/8"	8 x 3/4"	112.4
10"	6"	279	279	273.0	323.8	362.0	7.5	38.1	47.0	168.3	215.9	241.3	4.5	30.4	37.0	12 x 7/8"	8 x 3/4"	124.7
10"	8"	279	279	273.0	323.8	362.0	7.5	38.1	47.0	219.1	269.9	298.5	5.0	34.0	41.8	12 x 7/8"	8 x 3/4"	143.0
10"	10"	279	279	273.0	323.8	362.0	7.5	38.1	47.0	273.0	323.8	362.0	7.5	38.1	47.0	12 x 7/8"	12 x 7/8"	165.2
12"	6"	305	305	323.8	381.0	431.8	7.5	39.7	49.6	168.3	215.9	241.3	4.5	30.4	37.0	12 x 7/8"	8 x 3/4"	159.5
12"	8"	305	305	323.8	381.0	431.8	7.5	39.7	49.6	219.1	269.9	298.5	5.0	34.0	41.8	12 x 7/8"	8 x 3/4"	178.3
12"	10"	305	305	323.8	381.0	431.8	7.5	39.7	49.6	273.0	323.8	362.0	7.5	38.1	47.0	12 x 7/8"	12 x 7/8"	201.0
12"	12"	305	305	323.8	381.0	431.8	7.5	39.7	49.6	323.8	381.0	431.8	5.0	37.2	47.1	12 x 7/8"	12 x 7/8"	223.7
14"	8"	356	356	355.6	412.8	476.3	10.0	45.4	60.0	219.1	269.9	298.5	5.0	34.0	41.8	12 x 1"	8 x 3/4"	215.3
14"	10"	356	356	355.6	412.8	476.3	10.0	45.4	60.0	273.0	323.8	362.0	7.5	38.1	47.0	12 x 1"	12 x 7/8"	239.0
14"	12"	356	356	355.6	412.8	476.3	10.0	45.4	60.0	323.8	381.0	431.8	5.0	37.2	47.1	12 x 1"	12 x 7/8"	262.5
14"	14"	356	356	355.6	412.8	476.3	10.0	45.4	60.0	355.6	412.8	476.3	5.0	40.4	55.0	12 x 1"	12 x 1"	304.7

continued on the next page

Flanged Tees (Class 150)

NPS ₁	NPS ₂	L ₁	L ₂	d ₁₍₁₎	d ₄₍₁₎	K ₁₍₁₎	s _{min(1)}	a ₁₍₁₎	a ₂₍₁₎	d ₁₍₂₎	d ₄₍₂₎	K ₁₍₂₎	s _{min(2)}	a ₁₍₂₎	a ₂₍₂₎	No. of bolts x thread [UNC]		Wt. (ca. kg/pc.)
																NPS ₁	NPS ₂	
16"	10"	381	381	406.4	469.9	539.8	7.0	44.0	58.6	273.0	323.8	362.0	7.5	38.1	47.0	16 x 1"	12 x 7/8"	283.3
16"	12"	381	381	406.4	469.9	539.8	7.0	44.0	58.6	323.8	381.0	431.8	5.0	37.2	47.1	16 x 1"	12 x 7/8"	307.2
16"	14"	381	381	406.4	469.9	539.8	7.0	44.0	58.6	355.6	412.8	476.3	5.0	40.4	55.0	16 x 1"	12 x 1"	349.6
16"	16"	381	381	406.4	469.9	539.8	7.0	44.0	58.6	406.4	469.9	539.8	5.0	42.0	56.6	16 x 1"	16 x 1"	402.5
18"	12"	419	419	457.0	533.4	577.9	8.0	48.1	62.7	323.8	381.0	431.8	5.0	37.2	47.1	16 x 1 1/8"	12 x 7/8"	336.3
18"	14"	419	419	457.0	533.4	577.9	8.0	48.1	62.7	355.6	412.8	476.3	5.0	40.4	55.0	16 x 1 1/8"	12 x 1"	379.0
18"	16"	419	419	457.0	533.4	577.9	8.0	48.1	62.7	406.4	469.9	539.8	5.0	42.0	56.6	16 x 1 1/8"	16 x 1"	432.7
18"	18"	419	419	457.0	533.4	577.9	8.0	48.1	62.7	457.0	533.4	577.9	5.0	45.1	59.7	16 x 1 1/8"	16 x 1 1/8"	469.9
20"	12"	457	457	508.0	584.2	635.0	8.0	51.3	65.9	323.8	381.0	431.8	5.0	37.2	47.1	20 x 1 1/8"	12 x 7/8"	389.3
20"	14"	457	457	508.0	584.2	635.0	8.0	51.3	65.9	355.6	412.8	476.3	5.0	40.4	55.0	20 x 1 1/8"	12 x 1"	432.4
20"	16"	457	457	508.0	584.2	635.0	8.0	51.3	65.9	406.4	469.9	539.8	5.0	42.0	56.6	20 x 1 1/8"	16 x 1"	486.8
20"	18"	457	457	508.0	584.2	635.0	8.0	51.3	65.9	457.0	533.4	577.9	5.0	45.1	59.7	20 x 1 1/8"	16 x 1 1/8"	524.3
20"	20"	457	457	508.0	584.2	635.0	8.0	51.3	65.9	508.0	584.2	635.0	5.0	48.3	62.9	20 x 1 1/8"	20 x 1 1/8"	571.1

Different nominal pipe sizes and total lengths on request.

- L = Total length
 - d₁ = Outer diameter of the pipe
 - d₄ = Raised face diameter
 - K = Bolt circle diameter
 - s_{min} = Minimum flare thickness
 - a₁ = Minimum length with fixed flange and s_{min}
 - a₂ = Minimum length with loose flange and s_{min}
- Technical data valid for the pressure rating Class 150.
a1 and a2 depend on construction type and lining thickness.

NPS ₁	Lining thickness		Possible vacuum		
	standard	thick-walled	23° C	150° C	200° C
1"	●		▬	▬	▬
1 1/2"	●		▬	▬	▬
2"	●		▬	▬	▬
3"	●		▬	▬	▬
4"	●		▬	▬	▬
6"	●		▬	▬	▬
8"	●		▬	▬	▬
10"	●		▬	▬	▬
12"	●		▬	▬	▬

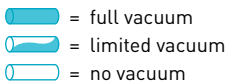
Vacuum resistance:

 ▬ = full vacuum
 ▬ = limited vacuum
 ▬ = no vacuum
 Please refer to the next higher nominal pipe size if your nominal pipe size is not listed.



Flanged Lateral Tees



Flanged Lateral Tees 45° (Class 150)

The one-piece design with PFA or PP lining offers a low-resistance flow through the entire component by a streamlined geometry.



Flanged Lateral Tees 45° (Class 150)

Materials:

- carbon steel
- stainless steel

Lining materials:

- PFA (virgin or conductive)
- PP

Flanges (reading order A-B-C):

- combinations of fixed flanges
- combinations of loose flanges
- combinations of fixed and loose flanges

Other pressure rating:

- Class 300

Special features:

- earthing stud/lug
- vent hole extension
- flange stopper

Optional extras:

- final painting
- non-destructive testing

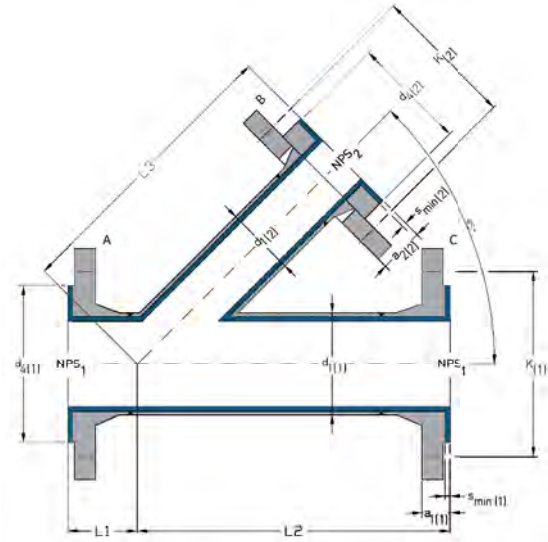

NPS ₁	NPS ₂	L ₁ (mm)	L ₂ =L ₃ (mm)	d ₁₍₁₎ (mm)	d ₄₍₁₎ (mm)	K ₁₍₁₎ (mm)	s _{min(1)} (mm)	a ₁₍₁₎ (mm)	a ₂₍₁₎ (mm)	d ₁₍₂₎ (mm)	d ₄₍₂₎ (mm)	K ₁₍₂₎ (mm)	s _{min(2)} (mm)	a ₁₍₂₎ (mm)	a ₂₍₂₎ (mm)	No. of bolts x thread (UNC)		Wt. (ca. kg/pc.)
																NPS ₁	NPS ₂	
1"	1"	44	146	33.4	50.8	79.4	4.0	18.7	22.3	33.4	50.8	79.4	4.0	18.7	22.3	4 x 1/2"	4 x 1/2"	3.9
1 1/2"	1 1/2"	51	178	48.3	73.0	98.4	4.0	21.9	25.5	48.3	73.0	98.4	4.0	21.9	25.5	4 x 1/2"	4 x 1/2"	6.9
2"	1"	64	203	60.3	92.1	120.7	4.0	23.5	27.6	33.4	50.8	79.4	4.0	18.7	22.3	4 x 5/8"	4 x 1/2"	8.3
2"	1 1/2"	64	203	60.3	92.1	120.7	4.0	23.5	27.6	48.3	73.0	98.4	4.0	21.9	25.5	4 x 5/8"	4 x 1/2"	9.3
2"	2"	64	203	60.3	92.1	120.7	4.0	23.5	27.6	60.3	92.1	120.7	4.0	23.5	27.6	4 x 5/8"	4 x 5/8"	10.5
3"	1"	76	254	88.9	127.0	152.4	4.0	28.3	33.4	33.4	50.8	79.4	4.0	18.7	22.3	4 x 5/8"	4 x 1/2"	15.5
3"	2"	76	254	88.9	127.0	152.4	4.0	28.3	33.4	60.3	92.1	120.7	4.0	23.5	27.6	4 x 5/8"	4 x 5/8"	17.7
3"	3"	76	254	88.9	127.0	152.4	4.0	28.3	33.4	88.9	127.0	152.4	4.0	28.3	33.4	4 x 5/8"	4 x 5/8"	21.3
4"	1"	76	305	114.3	157.2	190.5	4.0	28.3	33.9	33.4	50.8	79.4	4.0	18.7	22.3	8 x 5/8"	4 x 1/2"	21.8
4"	2"	76	305	114.3	157.2	190.5	4.0	28.3	33.9	60.3	92.1	120.7	4.0	23.5	27.6	8 x 5/8"	4 x 5/8"	24.2
4"	3"	76	305	114.3	157.2	190.5	4.0	28.3	33.9	88.9	127.0	152.4	4.0	28.3	33.4	8 x 5/8"	4 x 5/8"	28.0
4"	4"	76	305	114.3	157.2	190.5	4.0	28.3	33.9	114.3	157.2	190.5	4.0	28.3	33.9	8 x 5/8"	8 x 5/8"	31.1

continued on the next page



Flanged Lateral Tees 45° (Class 150)

NPS ₁	NPS ₂	Possible flanges							
		fix-fix-fix	fix-fix-loose	fix-loose-fix	loose-fix-fix	fix-loose-loose	loose-loose-fix	loose-fix-Los	loose-loose-loose
1"	1"	●	-	-	●	-	-	-	-
1½"	1½"	●	●	●	●	-	●	●	-
2"	1"	●	●	●	●	●	●	●	●
2"	1½"	●	●	●	●	-	●	●	-
2"	2"	●	-	-	●	-	-	-	-
3"	1"	●	●	●	●	●	●	●	●
3"	2"	●	●	●	●	●	●	●	●
3"	3"	●	-	-	●	-	-	-	-
4"	1"	●	●	●	●	●	●	●	●
4"	2"	●	●	●	●	●	●	●	●
4"	3"	●	●	●	●	-	●	●	-
4"	4"	●	-	-	●	-	-	-	-

Different nominal pipe sizes and total lengths on request.

- L = Total length
 - d₁ = Outer diameter of the pipe
 - d₄ = Raised face diameter
 - K = Bolt circle diameter
 - s_{min} = Minimum flare thickness
 - a₁ = Minimum length with fixed flange and s_{min}
 - a₂ = Minimum length with loose flange and s_{min}
- Technical data valid for the pressure rating Class 150.
a₁ and a₂ depend on construction type and lining thickness.

NPS ₁	Lining thickness		Possible vacuum		
	standard	thick-walled	23° C	150° C	200° C
1"	●		☐	☐	☐
		●	☐	☐	☐
1½"	●		☐	☐	☐
		●	☐	☐	☐
2"	●		☐	☐	☐
		●	☐	☐	☐
3"	●		☐	☐	☐
		●	☐	☐	☐
4"	●		☐	☐	☐
		●	☐	☐	☐

Vacuum resistance:
 = full vacuum
 = limited vacuum
 = no vacuum
 Please refer to the next higher nominal pipe size if your nominal pipe size is not listed.



Flanged Crosses



Flanged Crosses (Class 150)

The one-piece design with PFA or PP lining assures a perfect flow in all four directions. The manufacturing of our one-piece Flanged Crosses is done by injection moulding. For Flanged Crosses with nominal pipe sizes

larger than NPS, 4", we rely on our approved paste liner. Both manufacturing technologies assure a specially smooth and easy-to-clean surface.



Flanged Crosses (Class 150)

Materials:

- carbon steel
- stainless steel

Lining materials:

- up to nominal pipe size NPS₁ 4" (one-piece): PFA
- up to nominal pipe size NPS₁ 4" (one-piece): PP
- from nominal pipe size NPS₁ 5" (one-piece): on request
- from nominal pipe size NPS₁ 5" (three-piece): PTFE (virgin or conductive)

Flanges (reading order A-B-C-D):

- combinations of fixed flanges
- combinations of loose flanges
- combinations of fixed and loose flanges

Other pressure rating:

- Class 300

Special features:

- earthing stud/lug
- vent hole extension
- flange stopper

Optional extras:

- final painting
- non-destructive testing

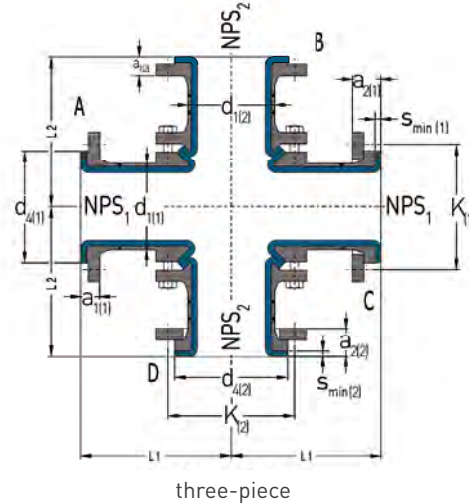
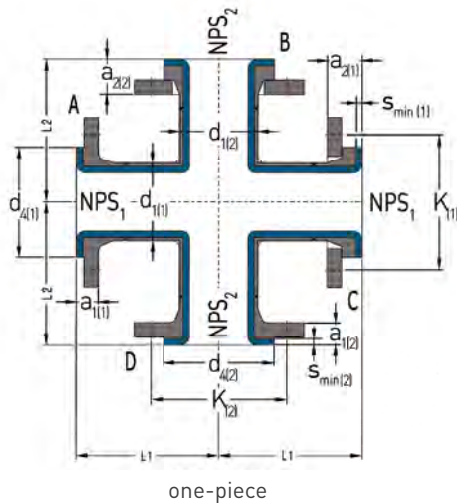

NPS ₁	NPS ₂	L ₁ (mm)	L ₂ (mm)	d ₁₍₁₎ (mm)	d ₄₍₁₎ (mm)	K ₁₍₁₎ (mm)	s _{min(1)} (mm)	a ₁₍₁₎ (mm)	a ₂₍₁₎ (mm)	d ₁₍₂₎ (mm)	d ₄₍₂₎ (mm)	K ₁₍₂₎ (mm)	s _{min(2)} (mm)	a ₁₍₂₎ (mm)	a ₂₍₂₎ (mm)	No. of bolts x thread (UNC)		Wt. (ca. kg/pc.)
																NPS ₁	NPS ₂	
1/2"	1/2"	65	65	26.7	34.9	60.3	4.0	15.6	19.2	26.7	34.9	60.3	4.0	15.6	19.2	4 x 1/2"	4 x 1/2"	2.3
3/4"	1/2"	75	75	26.7	42.9	69.9	4.0	17.2	20.7	26.7	34.9	60.3	4.0	15.6	19.2	4 x 1/2"	4 x 1/2"	3.2
3/4"	3/4"	75	75	26.7	42.9	69.9	4.0	17.2	20.7	26.7	42.9	69.9	4.0	17.2	20.7	4 x 1/2"	4 x 1/2"	3.9
1"	1/2"	89	89	33.4	50.8	79.4	4.0	18.7	22.3	26.7	34.9	60.3	4.0	15.6	19.2	4 x 1/2"	4 x 1/2"	4.1
1"	3/4"	89	89	33.4	50.8	79.4	4.0	18.7	22.3	26.7	42.9	69.9	4.0	17.2	20.7	4 x 1/2"	4 x 1/2"	4.9
1"	1"	89	89	33.4	50.8	79.4	4.0	18.7	22.3	33.4	50.8	79.4	4.0	18.7	22.3	4 x 1/2"	4 x 1/2"	5.7
1 1/4"	1/2"	95	95	42.2	63.5	88.9	4.0	20.3	23.9	26.7	34.9	60.3	4.0	15.6	19.2	4 x 1/2"	4 x 1/2"	5.2
1 1/4"	3/4"	95	95	42.2	63.5	88.9	4.0	20.3	23.9	26.7	42.9	69.9	4.0	17.2	20.7	4 x 1/2"	4 x 1/2"	5.9
1 1/4"	1"	95	95	42.2	63.5	88.9	4.0	20.3	23.9	33.4	50.8	79.4	4.0	18.7	22.3	4 x 1/2"	4 x 1/2"	6.8
1 1/4"	1 1/4"	95	95	42.2	63.5	88.9	4.0	20.3	23.9	42.2	63.5	88.9	4.0	20.3	23.9	4 x 1/2"	4 x 1/2"	7.7
1 1/2"	3/4"	102	102	48.3	73.0	98.4	4.0	21.9	25.5	26.7	42.9	69.9	4.0	17.2	20.7	4 x 1/2"	4 x 1/2"	6.0
1 1/2"	1"	102	102	48.3	73.0	98.4	4.0	21.9	25.5	33.4	50.8	79.4	4.0	18.7	22.3	4 x 1/2"	4 x 1/2"	6.7
1 1/2"	1 1/4"	102	102	48.3	73.0	98.4	4.0	21.9	25.5	42.2	63.5	88.9	4.0	20.3	23.9	4 x 1/2"	4 x 1/2"	7.5
1 1/2"	1 1/2"	102	102	48.3	73.0	98.4	4.0	21.9	25.5	48.3	73.0	98.4	4.0	21.9	25.5	4 x 1/2"	4 x 1/2"	8.4
2"	1"	114	114	60.3	92.1	120.7	4.0	23.5	27.6	33.4	50.8	79.4	4.0	18.7	22.3	4 x 5/8"	4 x 1/2"	9.0
2"	1 1/4"	114	114	60.3	92.1	120.7	4.0	23.5	27.6	42.2	63.5	88.9	4.0	20.3	23.9	4 x 5/8"	4 x 1/2"	9.8
2"	1 1/2"	114	114	60.3	92.1	120.7	4.0	23.5	27.6	48.3	73.0	98.4	4.0	21.9	25.5	4 x 5/8"	4 x 1/2"	10.7
2"	2"	114	114	60.3	92.1	120.7	4.0	23.5	27.6	60.3	92.1	120.7	4.0	23.5	27.6	4 x 5/8"	4 x 5/8"	12.8

continued on the next page

Flanged Crosses (Class 150)

NPS ₁	NPS ₂	L ₁ (mm)	L ₂ (mm)	d ₁₍₁₎ (mm)	d ₄₍₁₎ (mm)	K ₁₍₁₎ (mm)	s _{min(1)} (mm)	a ₁₍₁₎ (mm)	a ₂₍₁₎ (mm)	d ₁₍₂₎ (mm)	d ₄₍₂₎ (mm)	K ₁₍₂₎ (mm)	s _{min(2)} (mm)	a ₁₍₂₎ (mm)	a ₂₍₂₎ (mm)	No. of bolts x thread [UNC]		Wt. (ca. kg/pc.)
																NPS ₁	NPS ₂	
2½"	1"	127	127	73.0	104.8	139.7	4.0	26.7	31.5	33.4	50.8	79.4	4.0	18.7	22.3	4 x 5/8"	4 x 1/2"	12.9
2½"	1¼"	127	127	73.0	104.8	139.7	4.0	26.7	31.5	42.2	63.5	88.9	4.0	20.3	23.9	4 x 5/8"	4 x 1/2"	13.8
2½"	1½"	127	127	73.0	104.8	139.7	4.0	26.7	31.5	48.3	73.0	98.4	4.0	21.9	25.5	4 x 5/8"	4 x 1/2"	14.7
2½"	2"	127	127	73.0	104.8	139.7	4.0	26.7	31.5	60.3	92.1	120.7	4.0	23.5	27.6	4 x 5/8"	4 x 5/8"	16.9
2½"	2½"	127	127	73.0	104.8	139.7	4.0	26.7	31.5	73.0	104.8	139.7	4.0	26.7	31.5	4 x 5/8"	4 x 5/8"	20.6
3"	1"	140	140	88.9	127.0	152.4	4.0	28.3	33.4	33.4	50.8	79.4	4.0	18.7	22.3	4 x 5/8"	4 x 1/2"	15.6
3"	1½"	140	140	88.9	127.0	152.4	4.0	28.3	33.4	48.3	73.0	98.4	4.0	21.9	25.5	4 x 5/8"	4 x 1/2"	17.5
3"	2"	140	140	88.9	127.0	152.4	4.0	28.3	33.4	60.3	92.1	120.7	4.0	23.5	27.6	4 x 5/8"	4 x 5/8"	19.7
3"	2½"	140	140	88.9	127.0	152.4	4.0	28.3	33.4	73.0	104.8	139.7	4.0	26.7	31.5	4 x 5/8"	4 x 5/8"	23.4
3"	3"	140	140	88.9	127.0	152.4	4.0	28.3	33.4	88.9	127.0	152.4	4.0	28.3	33.4	4 x 5/8"	4 x 5/8"	25.8
4"	1"	165	165	114.3	157.2	190.5	4.0	28.3	33.9	33.4	50.8	79.4	4.0	18.7	22.3	8 x 5/8"	4 x 1/2"	21.7
4"	2"	165	165	114.3	157.2	190.5	4.0	28.3	33.9	60.3	92.1	120.7	4.0	23.5	27.6	8 x 5/8"	4 x 5/8"	25.9
4"	2½"	165	165	114.3	157.2	190.5	4.0	28.3	33.9	73.0	104.8	139.7	4.0	26.7	31.5	8 x 5/8"	4 x 5/8"	29.9
4"	3"	165	165	114.3	157.2	190.5	4.0	28.3	33.9	88.9	127.0	152.4	4.0	28.3	33.4	8 x 5/8"	4 x 5/8"	32.4
4"	4"	165	165	114.3	157.2	190.5	4.0	28.3	33.9	114.3	157.2	190.5	4.0	28.3	33.9	8 x 5/8"	8 x 5/8"	37.6
5"	2½"	190	190	141.3	185.7	215.9	5.0	29.3	35.5	73.0	104.8	139.7	3.0	25.7	30.5	8 x 3/4"	4 x 5/8"	51.1
5"	3"	190	190	141.3	185.7	215.9	5.0	29.3	35.5	88.9	127.0	152.4	3.0	27.3	32.4	8 x 3/4"	4 x 5/8"	55.5
5"	4"	190	190	141.3	185.7	215.9	5.0	29.3	35.5	114.3	157.2	190.5	3.0	27.3	32.9	8 x 3/4"	8 x 5/8"	64.2
5"	5"	190	190	141.3	185.7	215.9	5.0	29.3	35.5	141.3	185.7	215.9	4.0	28.3	34.5	8 x 3/4"	8 x 3/4"	73.5
6"	3"	203	203	168.3	215.9	241.3	7.0	32.9	39.5	88.9	127.0	152.4	3.0	27.3	32.4	8 x 3/4"	4 x 5/8"	63.0
6"	4"	203	203	168.3	215.9	241.3	7.0	32.9	39.5	114.3	157.2	190.5	3.0	27.3	32.9	8 x 3/4"	8 x 5/8"	71.8
6"	5"	203	203	168.3	215.9	241.3	7.0	32.9	39.5	141.3	185.7	215.9	4.0	28.3	34.5	8 x 3/4"	8 x 3/4"	81.3
6"	6"	203	203	168.3	215.9	241.3	7.0	32.9	39.5	168.3	215.9	241.3	4.5	30.4	37.0	8 x 3/4"	8 x 3/4"	96.3
8"	4"	229	229	219.1	269.9	298.5	6.0	35.0	42.8	114.3	157.2	190.5	3.0	27.3	32.9	8 x 3/4"	8 x 5/8"	94.0
8"	5"	229	229	219.1	269.9	298.5	6.0	35.0	42.8	141.3	185.7	215.9	4.0	28.3	34.5	8 x 3/4"	8 x 3/4"	103.9
8"	6"	229	229	219.1	269.9	298.5	6.0	35.0	42.8	168.3	215.9	241.3	4.5	30.4	37.0	8 x 3/4"	8 x 3/4"	119.4
8"	8"	229	229	219.1	269.9	298.5	6.0	35.0	42.8	219.1	269.9	298.5	5.0	34.0	41.8	8 x 3/4"	8 x 3/4"	147.2
10"	5"	279	279	273.0	323.8	362.0	7.5	38.1	47.0	141.3	185.7	215.9	4.0	28.3	34.5	12 x 7/8"	8 x 3/4"	133.7
10"	6"	279	279	273.0	323.8	362.0	7.5	38.1	47.0	168.3	215.9	241.3	4.5	30.4	37.0	12 x 7/8"	8 x 3/4"	150.0
10"	8"	279	279	273.0	323.8	362.0	7.5	38.1	47.0	219.1	269.9	298.5	5.0	34.0	41.8	12 x 7/8"	8 x 3/4"	179.6
10"	10"	279	279	273.0	323.8	362.0	7.5	38.1	47.0	273.0	323.8	362.0	7.5	38.1	47.0	12 x 7/8"	12 x 7/8"	212.9
12"	6"	305	305	323.8	381.0	431.8	7.5	39.7	49.6	168.3	215.9	241.3	4.5	30.4	37.0	12 x 7/8"	8 x 3/4"	188.2
12"	8"	305	305	323.8	381.0	431.8	7.5	39.7	49.6	219.1	269.9	298.5	5.0	34.0	41.8	12 x 7/8"	8 x 3/4"	218.7
12"	10"	305	305	323.8	381.0	431.8	7.5	39.7	49.6	273.0	323.8	362.0	7.5	38.1	47.0	12 x 7/8"	12 x 7/8"	253.2
12"	12"	305	305	323.8	381.0	431.8	7.5	39.7	49.6	323.8	381.0	431.8	5.0	37.2	47.1	12 x 7/8"	12 x 7/8"	293.3
14"	8"	356	356	355.6	412.8	476.3	10.0	45.4	60.0	219.1	269.9	298.5	5.0	34.0	41.8	12 x 1"	8 x 3/4"	261.4
14"	10"	356	356	355.6	412.8	476.3	10.0	45.4	60.0	273.0	323.8	362.0	7.5	38.1	47.0	12 x 1"	12 x 7/8"	298.1
14"	12"	356	356	355.6	412.8	476.3	10.0	45.4	60.0	323.8	381.0	431.8	5.0	37.2	47.1	12 x 1"	12 x 7/8"	339.9
14"	14"	356	356	355.6	412.8	476.3	10.0	45.4	60.0	355.6	412.8	476.3	5.0	40.4	55.0	12 x 1"	12 x 1"	397.2

continued on the next page

Flanged Crosses (Class 150)

NPS ₁	NPS ₂	L ₁ (mm)	L ₂ (mm)	d ₁₍₁₎ (mm)	d ₄₍₁₎ (mm)	K ₍₁₎ (mm)	s _{min(1)} (mm)	a ₁₍₁₎ (mm)	a ₂₍₁₎ (mm)	d ₁₍₂₎ (mm)	d ₄₍₂₎ (mm)	K ₍₂₎ (mm)	s _{min(2)} (mm)	a ₁₍₂₎ (mm)	a ₂₍₂₎ (mm)	No. of bolts x thread (UNC)		Wt. (ca. kg/pc.)
																NPS ₁	NPS ₂	
16"	10"	381	381	406.4	469.9	539.8	7.0	44.0	58.6	273.0	323.8	362.0	7.5	38.1	47.0	16 x 1"	12 x 7/8"	347.4
16"	12"	381	381	406.4	469.9	539.8	7.0	44.0	58.6	323.8	381.0	431.8	5.0	37.2	47.1	16 x 1"	12 x 7/8"	390.1
16"	14"	381	381	406.4	469.9	539.8	7.0	44.0	58.6	355.6	412.8	476.3	5.0	40.4	55.0	16 x 1"	12 x 1"	447.9
16"	16"	381	381	406.4	469.9	539.8	7.0	44.0	58.6	406.4	469.9	539.8	5.0	42.0	56.6	16 x 1"	16 x 1"	521.8
18"	12"	419	419	457.0	533.4	577.9	8.0	48.1	62.7	323.8	381.0	431.8	5.0	37.2	47.1	16 x 1 1/8"	12 x 7/8"	424.8
18"	14"	419	419	457.0	533.4	577.9	8.0	48.1	62.7	355.6	412.8	476.3	5.0	40.4	55.0	16 x 1 1/8"	12 x 1"	483.3
18"	16"	419	419	457.0	533.4	577.9	8.0	48.1	62.7	406.4	469.9	539.8	5.0	42.0	56.6	16 x 1 1/8"	16 x 1"	558.8
18"	18"	419	419	457.0	533.4	577.9	8.0	48.1	62.7	457.0	533.4	577.9	5.0	45.1	59.7	16 x 1 1/8"	16 x 1 1/8"	605.2
20"	12"	457	457	508.0	584.2	635.0	8.0	51.3	65.9	323.8	381.0	431.8	5.0	37.2	47.1	20 x 1 1/8"	12 x 7/8"	485.4
20"	14"	457	457	508.0	584.2	635.0	8.0	51.3	65.9	355.6	412.8	476.3	5.0	40.4	55.0	20 x 1 1/8"	12 x 1"	544.6
20"	16"	457	457	508.0	584.2	635.0	8.0	51.3	65.9	406.4	469.9	539.8	5.0	42.0	56.6	20 x 1 1/8"	16 x 1"	621.7
20"	18"	457	457	508.0	584.2	635.0	8.0	51.3	65.9	457.0	533.4	577.9	5.0	45.1	59.7	20 x 1 1/8"	16 x 1 1/8"	668.7
20"	20"	457	457	508.0	584.2	635.0	8.0	51.3	65.9	508.0	584.2	635.0	5.0	48.3	62.9	20 x 1 1/8"	20 x 1 1/8"	738.9

Different nominal pipe sizes and total lengths on request.

- L = Total length
 - d₁ = Outer diameter of the pipe
 - d₄ = Raised face diameter
 - K = Bolt circle diameter
 - s_{min} = Minimum flare thickness
 - a₁ = Minimum length with fixed flange and s_{min}
 - a₂ = Minimum length with loose flange and s_{min}
- Technical data valid for the pressure rating Class 150.
a₁ and a₂ depend on construction type and lining thickness.

NPS ₁	Lining thickness		Possible vacuum		
	standard	thick-walled	23° C	150° C	200° C
1"	●		☐	☐	☐
1 1/2"	●		☐	☐	☐
2"	●		☐	☐	☐
3"	●		☐	☐	☐
4"	●		☐	☐	☐
6"	●		☐	☐	☐
8"	●		☐	☐	☐
10"	●		☐	☐	☐
12"	●		☐	☐	☐

Vacuum resistance:

- ☐ = full vacuum
- ☐ = limited vacuum
- ☐ = no vacuum

Please refer to the next higher nominal pipe size if your nominal pipe size is not listed.



Instrument Tees

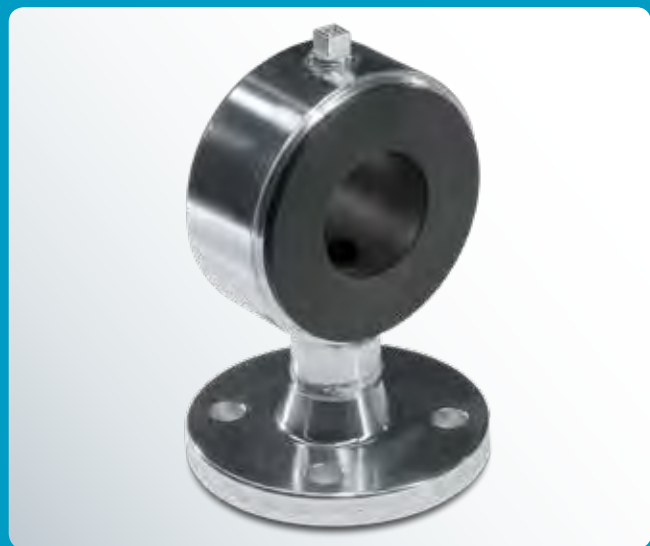

Instrument Tees (Class 150)

Instrument Tees, also known as gauge connections, are the one-piece solution with PFA or PP lining for the connection to your measuring devices. In case of narrow space, also useable as short tee.

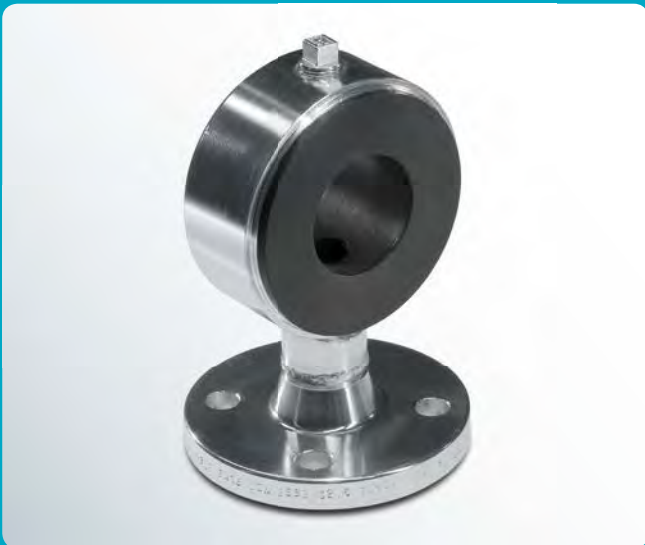

Instrument Tees (Class 150)

Materials:

- carbon steel
- stainless steel

Lining materials:

- PFA (virgin or conductive)
- PP

Other pressure rating:

- Class 300

Special features:

- earthing stud/lug
- vent hole extension

Optional extras:

- final painting

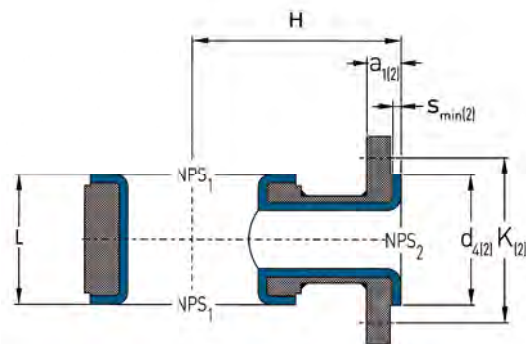

NPS ₁	NPS ₂	L (mm)	H (mm)	d ₄₍₂₎ (mm)	K ₍₂₎ (mm)	S _{min(2)} (mm)	a ₁₍₂₎ (mm)	No. of bolts x thread (UNC) NPS ₂	Weights (ca. kg/piece)
1"	1/2"	50	90	34.9	60.3	4.0	15.6	4 x 1/2"	1.5
1"	3/4"	50	90	42.9	69.9	4.0	17.2	4 x 1/2"	1.8
1"	1"	50	90	50.8	79.4	4.0	18.7	4 x 1/2"	2.1
1 1/4"	1/2"	50	100	34.9	60.3	4.0	15.6	4 x 1/2"	1.4
1 1/4"	3/4"	50	100	42.9	69.9	4.0	17.2	4 x 1/2"	1.7
1 1/4"	1"	50	100	50.8	79.4	4.0	18.7	4 x 1/2"	2.0
1 1/2"	1/2"	50	110	34.9	60.3	4.0	15.6	4 x 1/2"	2.1
1 1/2"	3/4"	50	110	42.9	69.9	4.0	17.2	4 x 1/2"	2.4
1 1/2"	1"	50	110	50.8	79.4	4.0	18.7	4 x 1/2"	2.7
1 1/2"	1 1/2"	75	110	73.0	98.4	4.0	21.9	4 x 1/2"	4.4
2"	1/2"	50	115	34.9	60.3	4.0	15.6	4 x 1/2"	2.8
2"	3/4"	50	115	42.9	69.9	4.0	17.2	4 x 1/2"	3.1
2"	1"	50	115	50.8	79.4	4.0	18.7	4 x 1/2"	3.4
2"	1 1/2"	75	115	73.0	98.4	4.0	21.9	4 x 1/2"	5.5
2"	2"	90	115	92.1	120.7	4.0	23.5	4 x 5/8"	7.2
2 1/2"	1/2"	50	125	34.9	60.3	4.0	15.6	4 x 1/2"	2.9
2 1/2"	3/4"	50	125	42.9	69.9	4.0	17.2	4 x 1/2"	3.2
2 1/2"	1"	50	125	50.8	79.4	4.0	18.7	4 x 1/2"	3.5
2 1/2"	1 1/2"	75	125	73.0	98.4	4.0	21.9	4 x 1/2"	5.7
2 1/2"	2"	90	125	92.1	120.7	4.0	23.5	4 x 5/8"	7.4
3"	1/2"	50	135	34.9	60.3	4.0	15.6	4 x 1/2"	4.0
3"	3/4"	50	135	42.9	69.9	4.0	17.2	4 x 1/2"	4.3
3"	1"	50	135	50.8	79.4	4.0	18.7	4 x 1/2"	4.6
3"	1 1/2"	75	135	73.0	98.4	4.0	21.9	4 x 1/2"	7.4
3"	2"	90	135	92.1	120.7	4.0	23.5	4 x 5/8"	9.6
4"	1/2"	50	150	34.9	60.3	4.0	15.6	4 x 1/2"	5.0
4"	3/4"	50	150	42.9	69.9	4.0	17.2	4 x 1/2"	5.3
4"	1"	50	150	50.8	79.4	4.0	18.7	4 x 1/2"	5.6
4"	1 1/2"	75	150	73.0	98.4	4.0	21.9	4 x 1/2"	9.0
4"	2"	90	150	92.1	120.7	4.0	23.5	4 x 5/8"	13.7
5"	1/2"	50	160	34.9	60.3	4.0	15.6	4 x 1/2"	6.5
5"	3/4"	50	160	42.9	69.9	4.0	17.2	4 x 1/2"	6.8
5"	1"	50	160	50.8	79.4	4.0	18.7	4 x 1/2"	7.1
5"	1 1/2"	75	160	73.0	98.4	4.0	21.9	4 x 1/2"	11.4
5"	2"	90	160	92.1	120.7	4.0	23.5	4 x 5/8"	14.4

continued on the next page

Instrument Tees (Class 150)

NPS ₁	NPS ₂	L	H	d ₄₍₂₎	K ₍₂₎	s _{min (2)}	a ₁₍₂₎	No. of bolts x thread (UNC) NPS ₂	Weights (ca. kg/piece)
		(mm)	(mm)	(mm)	(mm)	(mm)	(mm)		
6"	1/2"	50	180	34.9	60.3	4.0	15.6	4 x 1/2"	7.9
6"	3/4"	50	180	42.9	69.9	4.0	17.2	4 x 1/2"	8.2
6"	1"	50	180	50.8	79.4	4.0	18.7	4 x 1/2"	8.5
6"	1 1/2"	75	180	73.0	98.4	4.0	21.9	4 x 1/2"	13.5
6"	2"	90	180	92.1	120.7	4.0	23.5	4 x 5/8"	17.0
8"	1/2"	50	210	34.9	60.3	4.0	15.6	4 x 1/2"	10.5
8"	3/4"	50	210	42.9	69.9	4.0	17.2	4 x 1/2"	10.8
8"	1"	50	210	50.8	79.4	4.0	18.7	4 x 1/2"	11.2
8"	1 1/2"	75	210	73.0	98.4	4.0	21.9	4 x 1/2"	17.7
8"	2"	90	210	92.1	120.7	4.0	23.5	4 x 5/8"	22.1
10"	1"	50	240	50.8	79.4	4.0	18.7	4 x 1/2"	13.5
10"	1 1/2"	75	240	73.0	98.4	4.0	21.9	4 x 1/2"	21.4
10"	2"	90	240	92.1	120.7	4.0	23.5	4 x 5/8"	26.6
12"	1"	50	340	50.8	79.4	4.0	18.7	4 x 1/2"	22.7
12"	1 1/2"	75	340	73.0	98.4	4.0	21.9	4 x 1/2"	30.3
12"	2"	90	340	92.1	120.7	4.0	23.5	4 x 5/8"	37.5
14"	1"	90	375	50.8	79.4	4.0	18.7	4 x 1/2"	47.0
14"	1 1/2"	110	375	73.0	98.4	4.0	21.9	4 x 1/2"	2.9
14"	2"	120	375	92.1	120.7	4.0	23.5	4 x 5/8"	65.5
16"	1"	90	390	50.8	79.4	4.0	18.7	4 x 1/2"	53.3
16"	1 1/2"	110	390	73.0	98.4	4.0	21.9	4 x 1/2"	66.6
16"	2"	120	390	92.1	120.7	4.0	23.5	4 x 5/8"	73.9
18"	1"	90	425	50.8	79.4	4.0	18.7	4 x 1/2"	49.9
18"	1 1/2"	110	425	73.0	98.4	4.0	21.9	4 x 1/2"	62.4
18"	2"	120	425	92.1	120.7	4.0	23.5	4 x 5/8"	69.3
20"	1"	90	450	50.8	79.4	4.0	18.7	4 x 1/2"	74.0
20"	1 1/2"	110	450	73.0	98.4	4.0	21.9	4 x 1/2"	92.5
20"	2"	120	450	92.1	120.7	4.0	23.5	4 x 5/8"	102.3

NPS ₁	Lining thickness		Possible vacuum		
	standard	thick-walled	23° C	150° C	200° C
1"	●	●			
1 1/2"	●	●			
2"	●	●			
3"	●	●			
4"	●	●			
6"	●	●			
8"	●	●			
10"	●	●			
12"	●	●			

Vacuum resistance:
 = full vacuum
 = limited vacuum
 = no vacuum
Please refer to the next higher nominal pipe size if your nominal pipe size is not listed.

Different nominal pipe sizes and total lengths on request.

- L = Total length
- H = Overall height
- d₄ = Raised face diameter
- K = Bolt circle diameter
- s_{min} = Minimum flare thickness
- a₁ = Minimum length with fixed flange and s_{min}

Technical data valid for the pressure rating Class 150.

a₁ depends on construction type and lining thickness.



Reducers



Reducing Flanges (Class 150)

We have a custom-made solution for transitions between all nominal pipe sizes. Depending on the reduction, lined with PTFE, PFA or PP.

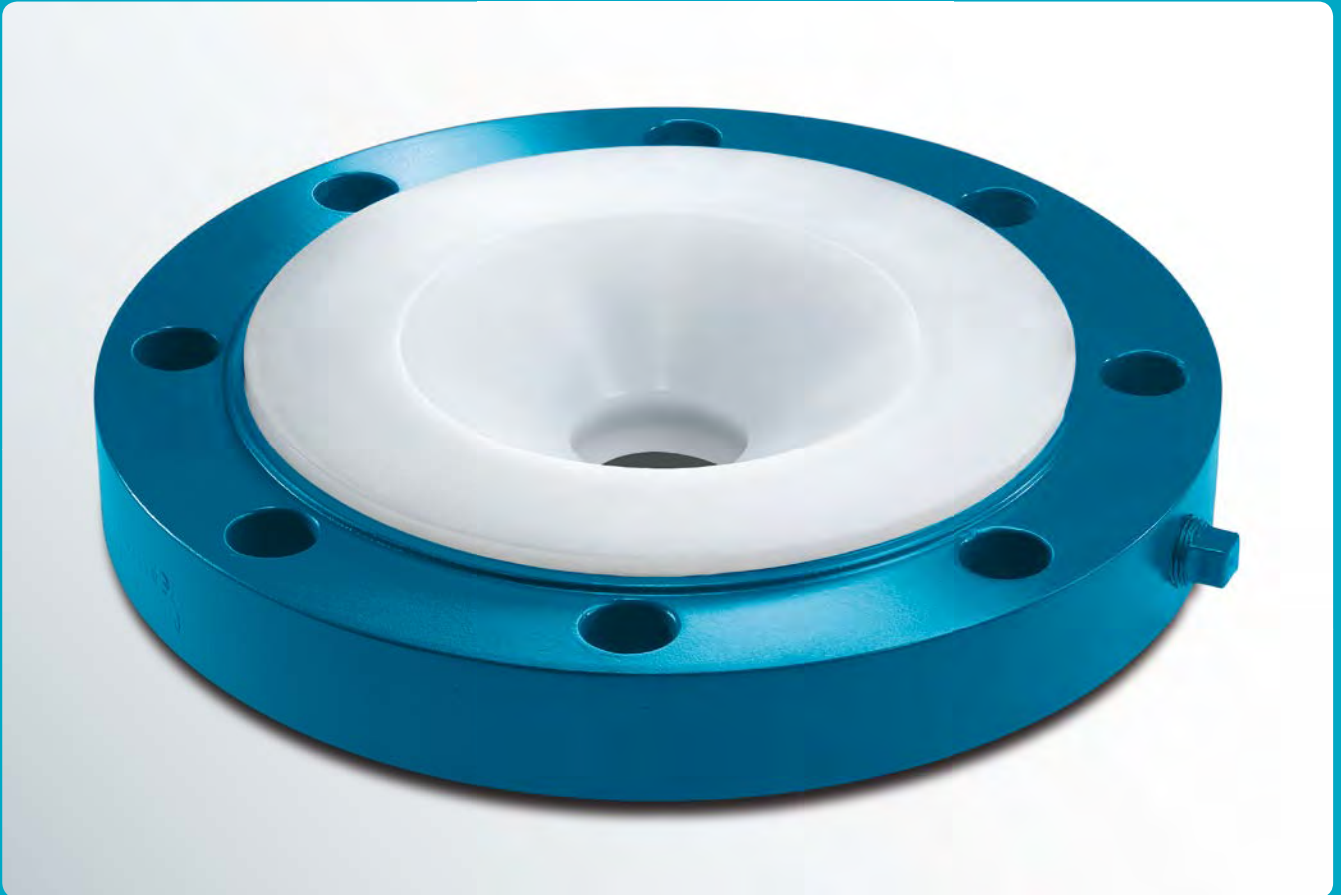

Reducing Flanges (Class 150)

Materials:

- carbon steel
- stainless steel

Lining materials:

- PTFE (virgin or conductive)
- PFA (virgin or conductive)
- PP

Other pressure rating:

- Class 300

Special features:

- earthing stud/lug

Optional extras:

- final painting

Form K1 (concentric):

- NPS₁: through holes
- NPS₂: threaded holes

Form K2 (concentric):

- NPS₁: threaded holes
- NPS₂: threaded holes

Form K3 (concentric):

- NPS₁: threaded holes
- NPS₂: threaded holes on centre line

Excentric **Reducing Flanges** – Form E2 and E3 according to DIN 2848 – on request.

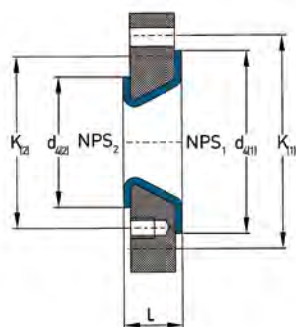

Form K1

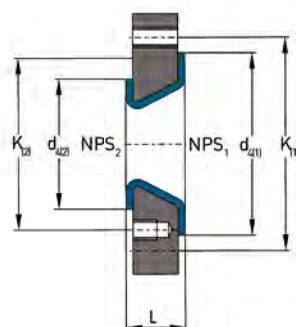

Form K2

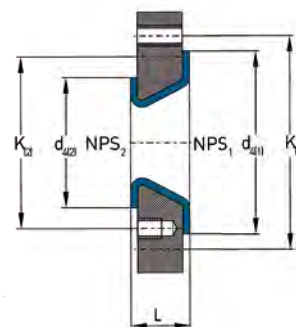

Form K3

NPS ₁	NPS ₂	L (mm)	Form	d ₄₍₁₎ (mm)	K ₁₍₁₎ (mm)	d ₄₍₂₎ (mm)	K ₁₍₂₎ (mm)	Lining materials	No. of bolts x thread (UNC)		Weights (ca. kg/piece)
									NPS ₁	NPS ₂	
3/4"	1/2"	35	K3	42.9	69.9	34.9	60.3	PTFE	4 x 1/2"	4 x 1/2"	1.8
1"	1/2"	35	K3	50.8	79.4	34.9	60.3	PTFE	4 x 1/2"	4 x 1/2"	2.2
1"	3/4"	35	K3	50.8	79.4	42.9	69.9	PTFE	4 x 1/2"	4 x 1/2"	2.1
1 1/4"	3/4"	35	K3	63.5	88.9	42.9	69.9	PTFE	4 x 1/2"	4 x 1/2"	2.5
1 1/4"	1"	35	K3	63.5	88.9	50.8	79.4	PTFE	4 x 1/2"	4 x 1/2"	2.5
1 1/2"	3/4"	35	K2	73.0	98.4	42.9	69.9	PFA	4 x 1/2"	4 x 1/2"	3.1
1 1/2"	1"	35	K3	73.0	98.4	50.8	79.4	PTFE	4 x 1/2"	4 x 1/2"	3.0
1 1/2"	1 1/4"	35	K3	73.0	98.4	63.5	88.9	PTFE	4 x 1/2"	4 x 1/2"	3.0
2"	3/4"	35	K2	92.1	120.7	42.9	69.9	PFA	4 x 5/8"	4 x 1/2"	4.2
2"	1"	35	K2	92.1	120.7	50.8	79.4	PFA	4 x 5/8"	4 x 1/2"	4.2
2"	1 1/4"	35	K3	92.1	120.7	63.5	88.9	PTFE	4 x 5/8"	4 x 1/2"	3.8
2"	1 1/2"	35	K3	92.1	120.7	73.0	98.4	PTFE	4 x 5/8"	4 x 1/2"	3.8
2 1/2"	3/4"	35	K2	104.8	139.7	42.9	69.9	PFA	4 x 5/8"	4 x 1/2"	5.8
2 1/2"	1"	35	K2	104.8	139.7	50.8	79.4	PFA	4 x 5/8"	4 x 1/2"	5.7
2 1/2"	1 1/4"	35	K2	104.8	139.7	63.5	88.9	PFA	4 x 5/8"	4 x 1/2"	5.6
2 1/2"	1 1/2"	35	K3	104.8	139.7	73.0	98.4	PTFE	4 x 5/8"	4 x 1/2"	5.3
2 1/2"	2"	35	K3	104.8	139.7	92.1	120.7	PTFE	4 x 5/8"	4 x 5/8"	5.2
3"	1"	35	K1	127.0	152.4	50.8	79.4	PFA	4 x 5/8"	4 x 1/2"	6.4
3"	1 1/4"	35	K2	127.0	152.4	63.5	88.9	PFA	4 x 5/8"	4 x 1/2"	6.4
3"	1 1/2"	35	K2	127.0	152.4	73.0	98.4	PFA	4 x 5/8"	4 x 1/2"	6.3
3"	2"	35	K2	127.0	152.4	92.1	120.7	PTFE	4 x 5/8"	4 x 5/8"	5.9
3"	2 1/2"	35	K2	127.0	152.4	104.8	139.7	PTFE	4 x 5/8"	4 x 5/8"	5.8

continued on the next page

Reducing Flanges (Class 150)

NPS ₁	NPS ₂	L (mm)	Form	d ₄₍₁₎ (mm)	K ₍₁₎ (mm)	d ₄₍₂₎ (mm)	K ₍₂₎ (mm)	Lining materials	No. of bolts x thread (UNC)		Weights (ca. kg/piece)
									NPS ₁	NPS ₂	
4"	1"	45	K1	157.2	190.5	50.8	79.4	PFA	8 x 5/8"	4 x 1/2"	11.6
4"	1 1/4"	45	K1	157.2	190.5	63.5	88.9	PFA	8 x 5/8"	4 x 1/2"	11.6
4"	1 1/2"	45	K1	157.2	190.5	73.0	98.4	PFA	8 x 5/8"	4 x 1/2"	11.5
4"	2"	45	K2	157.2	190.5	92.1	120.7	PFA	8 x 5/8"	4 x 5/8"	11.4
4"	2 1/2"	45	K2	157.2	190.5	104.8	139.7	PTFE	8 x 5/8"	4 x 5/8"	10.7
4"	3"	45	K3	157.2	190.5	127.0	152.4	PTFE	8 x 5/8"	4 x 5/8"	10.5
5"	1"	45	K1	185.7	215.9	50.8	79.4	PFA	8 x 3/4"	4 x 1/2"	13.8
5"	1 1/4"	45	K1	185.7	215.9	63.5	88.9	PFA	8 x 3/4"	4 x 1/2"	13.4
5"	1 1/2"	45	K1	185.7	215.9	73.0	98.4	PFA	8 x 3/4"	4 x 1/2"	13.4
5"	2"	45	K1	185.7	215.9	92.1	120.7	PFA	8 x 3/4"	4 x 5/8"	13.1
5"	2 1/2"	45	K2	185.7	215.9	104.8	139.7	PFA	8 x 3/4"	4 x 5/8"	12.8
5"	3"	45	K2	185.7	215.9	127.0	152.4	PTFE	8 x 3/4"	4 x 5/8"	11.8
5"	4"	45	K3	185.7	215.9	157.2	190.5	PTFE	8 x 3/4"	8 x 5/8"	11.4
6"	1"	45	K1	215.9	241.3	50.8	79.4	PFA	8 x 3/4"	4 x 1/2"	16.3
6"	1 1/4"	45	K1	215.9	241.3	63.5	88.9	PFA	8 x 3/4"	4 x 1/2"	16.6
6"	1 1/2"	45	K1	215.9	241.3	73.0	98.4	PFA	8 x 3/4"	4 x 1/2"	16.5
6"	2"	45	K1	215.9	241.3	92.1	120.7	PFA	8 x 3/4"	4 x 5/8"	16.5
6"	2 1/2"	45	K1	215.9	241.3	104.8	139.7	PFA	8 x 3/4"	4 x 5/8"	16.1
6"	3"	45	K1	215.9	241.3	127.0	152.4	PFA	8 x 3/4"	4 x 5/8"	15.6
6"	4"	45	K2	215.9	241.3	157.2	190.5	PTFE	8 x 3/4"	8 x 5/8"	13.7
6"	5"	45	K3	215.9	241.3	185.7	215.9	PTFE	8 x 3/4"	8 x 3/4"	13.5
8"	2"	45	K1	269.9	298.5	92.1	120.7	PFA	8 x 3/4"	4 x 5/8"	24.9
8"	2 1/2"	45	K1	269.9	298.5	104.8	139.7	PFA	8 x 3/4"	4 x 5/8"	26.0
8"	3"	45	K1	269.9	298.5	127.0	152.4	PFA	8 x 3/4"	4 x 5/8"	24.9
8"	4"	45	K1	269.9	298.5	157.2	190.5	PFA	8 x 3/4"	8 x 5/8"	25.0
8"	5"	45	K1	269.9	298.5	185.7	215.9	PTFE	8 x 3/4"	8 x 3/4"	23.1
8"	6"	45	K2	269.9	298.5	215.9	241.3	PTFE	8 x 3/4"	8 x 3/4"	21.9
10"	2 1/2"	45	K1	323.8	362.0	104.8	139.7	PFA	12 x 7/8"	4 x 5/8"	39.2
10"	3"	45	K1	323.8	362.0	127.0	152.4	PFA	12 x 7/8"	4 x 5/8"	37.5
10"	4"	45	K1	323.8	362.0	157.2	190.5	PFA	12 x 7/8"	8 x 5/8"	36.3
10"	5"	45	K1	323.8	362.0	185.7	215.9	PTFE	12 x 7/8"	8 x 3/4"	30.4
10"	6"	45	K1	323.8	362.0	215.9	241.3	PTFE	12 x 7/8"	8 x 3/4"	30.4
10"	8"	45	K2	323.8	362.0	269.9	298.5	PTFE	12 x 7/8"	8 x 3/4"	27.5
12"	3"	50	K1	381.0	431.8	127.0	152.4	PTFE	12 x 7/8"	4 x 5/8"	55.1
12"	4"	50	K1	381.0	431.8	157.2	190.5	PTFE	12 x 7/8"	8 x 5/8"	53.4
12"	5"	50	K1	381.0	431.8	185.7	215.9	PTFE	12 x 7/8"	8 x 3/4"	51.0
12"	6"	50	K1	381.0	431.8	215.9	241.3	PTFE	12 x 7/8"	8 x 3/4"	50.8
12"	8"	50	K1	381.0	431.8	269.9	298.5	PTFE	12 x 7/8"	8 x 3/4"	48.9
12"	10"	50	K2	381.0	431.8	323.8	362.0	PTFE	12 x 7/8"	12 x 7/8"	46.7
14"	4"	50	K1	412.8	476.3	157.2	190.5	PTFE	12 x 1"	8 x 5/8"	64.3
14"	5"	50	K1	412.8	476.3	185.7	215.9	PTFE	12 x 1"	8 x 3/4"	62.9
14"	6"	50	K1	412.8	476.3	215.9	241.3	PTFE	12 x 1"	8 x 3/4"	62.6
14"	8"	50	K1	412.8	476.3	269.9	298.5	PTFE	12 x 1"	8 x 3/4"	60.8
14"	10"	50	K1	412.8	476.3	323.8	362.0	PTFE	12 x 1"	12 x 7/8"	56.2
14"	12"	50	K2	412.8	476.3	381.0	431.8	PTFE	12 x 1"	12 x 7/8"	53.1

continued on the next page



Reducing Flanges (Class 150)

NPS ₁	NPS ₂	L (mm)	Form	d ₄₍₁₎ (mm)	K ₍₁₎ (mm)	d ₄₍₂₎ (mm)	K ₍₂₎ (mm)	Lining materials	No. of bolts x thread (UNC)		Weights (ca. kg/piece)
									NPS ₁	NPS ₂	
16"	5"	50	K1	469.9	539.8	185.7	215.9	PTFE	16 x 1"	8 x ¾"	84.1
16"	6"	50	K1	469.9	539.8	215.9	241.3	PTFE	16 x 1"	8 x ¾"	81.7
16"	8"	50	K1	469.9	539.8	269.9	298.5	PTFE	16 x 1"	8 x ¾"	76.7
16"	10"	50	K1	469.9	539.8	323.8	362.0	PTFE	16 x 1"	12 x 7/8"	76.4
16"	12"	50	K1	469.9	539.8	381.0	431.8	PTFE	16 x 1"	12 x 7/8"	68.3
16"	14"	50	K2	469.9	539.8	412.8	476.3	PTFE	16 x 1"	12 x 1"	63.6
18"	6"	50	K1	533.4	577.9	215.9	241.3	PTFE	16 x 1½"	8 x ¾"	80.2
18"	8"	50	K1	533.4	577.9	269.9	298.5	PTFE	16 x 1½"	8 x ¾"	78.4
18"	10"	50	K1	533.4	577.9	323.8	362.0	PTFE	16 x 1½"	12 x 7/8"	76.1
18"	12"	50	K1	533.4	577.9	381.0	431.8	PTFE	16 x 1½"	12 x 7/8"	73.8
18"	14"	50	K1	533.4	577.9	412.8	476.3	PTFE	16 x 1½"	12 x 1"	72.2
18"	16"	50	K2	533.4	577.9	469.9	539.8	PTFE	16 x 1½"	16 x 1"	69.4
20"	6"	50	K1	584.2	635.0	215.9	241.3	PTFE	20 x 1½"	8 x ¾"	115.0
20"	8"	50	K1	584.2	635.0	269.9	298.5	PTFE	20 x 1½"	8 x ¾"	110.3
20"	10"	50	K1	584.2	635.0	323.8	362.0	PTFE	20 x 1½"	12 x 7/8"	104.5
20"	12"	50	K1	584.2	635.0	381.0	431.8	PTFE	20 x 1½"	12 x 7/8"	100.5
20"	14"	50	K1	584.2	635.0	412.8	476.3	PTFE	20 x 1½"	12 x 1"	95.2
20"	16"	50	K1	584.2	635.0	469.9	539.8	PTFE	20 x 1½"	16 x 1"	87.6

Different nominal pipe sizes and total lengths on request.

L = Total length
d₄ = Raised face diameter
K = Bolt circle diameter
Technical data valid for the pressure rating Class 150.

NPS	Lining thickness		Possible vacuum		
	standard	thick-walled	23° C	150° C	200° C
1"	●	●	○	○	○
1½"	●	●	○	○	○
2"	●	●	○	○	○
3"	●	●	○	○	○
4"	●	●	○	○	○
6"	●	●	○	○	○
8"	●	●	○	○	○
10"	●	●	○	○	○
12"	●	●	○	○	○

Vacuum resistance:
 = full vacuum
 = limited vacuum
 = no vacuum
Please refer to the next higher nominal pipe size if your nominal pipe size is not listed.

Flanged Reducers concentric (Class 150)

Concentric Flanged Reducers are the universal solution for all changes of the nominal pipe size. Depending on the nominal width, the reducers are lined with PTFE, PFA or PP.

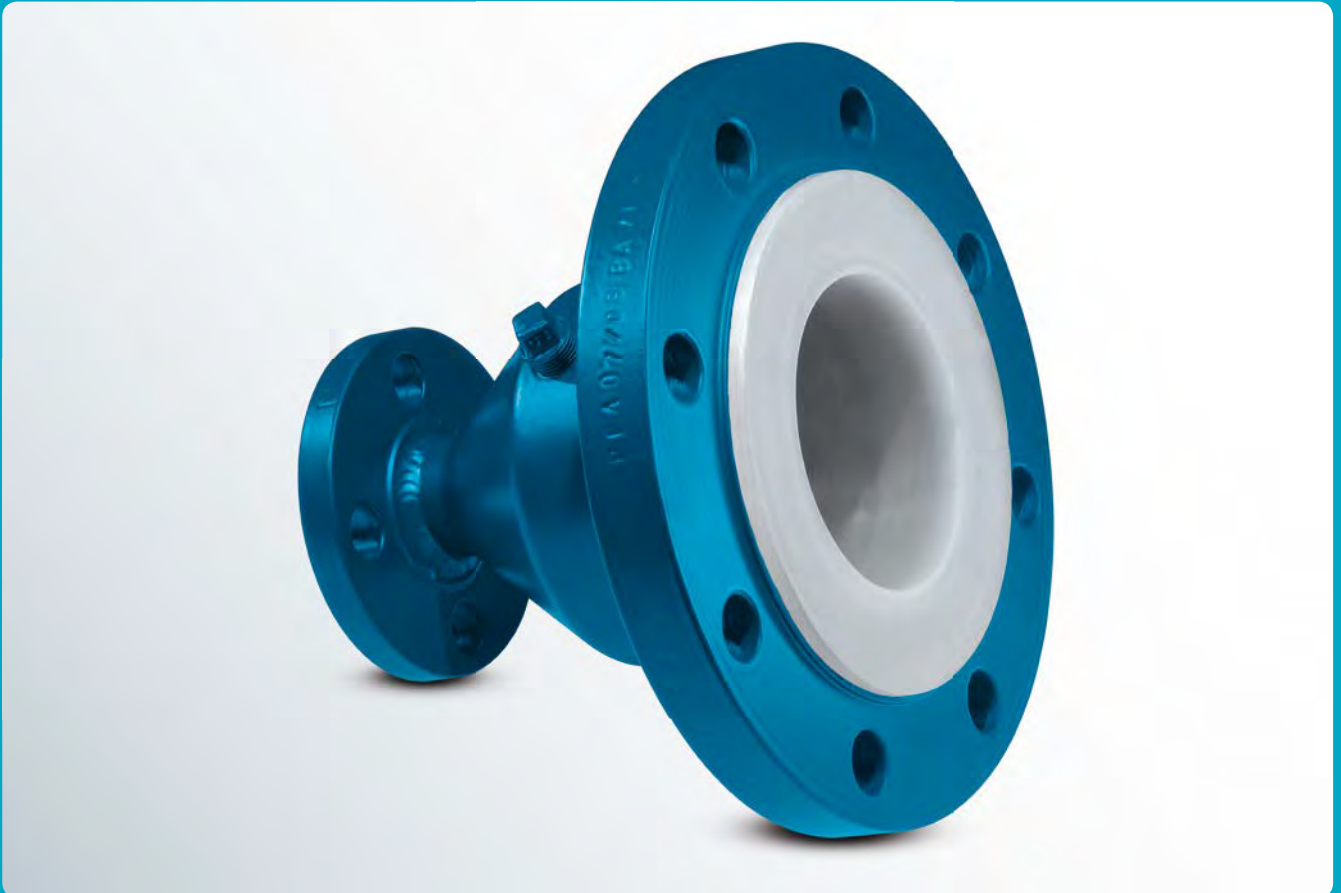

Flanged Reducers concentric (Class 150)

Materials:

- carbon steel
- stainless steel

Lining materials:

- PTFE (virgin or conductive)
- PFA (virgin or conductive)
- PP

Flanges:

- fix-fix
- fix-loose
- loose-loose

Other pressure rating:

- Class 300

Special features:

- earthing stud/ lug
- vent hole extension

Optional extras:

- final painting
- non-destructive testing

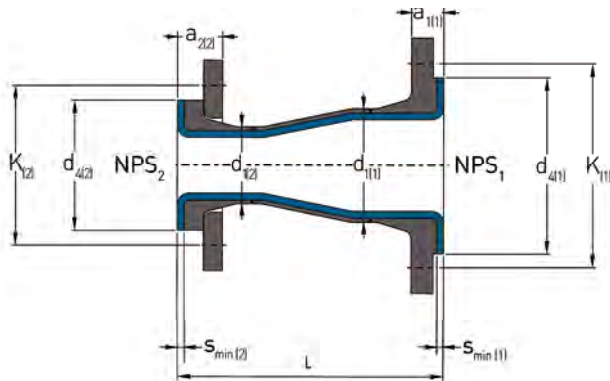

one-piece

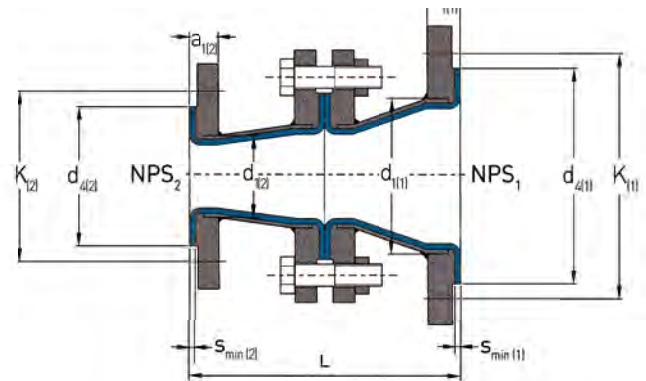

two-piece

NPS ₁	NPS ₂	L (mm)	d ₁₍₁₎ (mm)	d ₄₍₁₎ (mm)	K ₁₍₁₎ (mm)	s _{min(1)} (mm)	a ₁₍₁₎ (mm)	a ₂₍₁₎ (mm)	d ₁₍₂₎ (mm)	d ₄₍₂₎ (mm)	K ₁₍₂₎ (mm)	s _{min(2)} (mm)	a ₁₍₂₎ (mm)	a ₂₍₂₎ (mm)	Lining materials	No. of bolts x thread [UNC]		Wt. [ca. kg/pc.]
																NPS ₁	NPS ₂	
¾"	½"	114	26.7	42.9	69.9	3.0	16.2	19.7	26.7	34.9	60.3	3.0	14.6	18.2	PTFE	4 x ½"	4 x ½"	1.5
1"	½"	114	33.4	50.8	79.4	3.0	17.7	21.3	26.7	34.9	60.3	3.0	14.6	18.2	PTFE	4 x ½"	4 x ½"	1.9
1"	¾"	114	33.4	50.8	79.4	3.0	17.7	21.3	26.7	42.9	69.9	3.0	16.2	19.7	PTFE	4 x ½"	4 x ½"	2.2
1¼"	¾"	114	42.2	63.5	88.9	3.0	19.3	22.9	26.7	42.9	69.9	3.0	16.2	19.7	PTFE	4 x ½"	4 x ½"	2.7
1¼"	1"	114	42.2	63.5	88.9	3.0	19.3	22.9	33.4	50.8	79.4	3.0	17.7	21.3	PTFE	4 x ½"	4 x ½"	3.0
1½"	¾"	114	48.3	73.0	98.4	4.0	21.9	25.5	26.7	42.9	69.9	4.0	17.2	20.7	PFA	4 x ½"	4 x ½"	2.9
1½"	1"	114	48.3	73.0	98.4	3.0	20.9	24.5	33.4	50.8	79.4	3.0	17.7	21.3	PTFE	4 x ½"	4 x ½"	3.3
1½"	1¼"	114	48.3	73.0	98.4	3.0	20.9	24.5	42.2	63.5	88.9	3.0	19.3	22.9	PTFE	4 x ½"	4 x ½"	3.7
2"	1"	127	60.3	92.1	120.7	4.0	23.5	27.6	33.4	50.8	79.4	4.0	18.7	22.3	PFA	4 x ⅝"	4 x ½"	4.5
2"	1¼"	127	60.3	92.1	120.7	3.0	22.5	26.6	42.2	63.5	88.9	3.0	19.3	22.9	PTFE	4 x ⅝"	4 x ½"	5.0
2"	1½"	127	60.3	92.1	120.7	3.0	22.5	26.6	48.3	73.0	98.4	3.0	20.9	24.5	PTFE	4 x ⅝"	4 x ½"	5.0
2½"	1¼"	140	73.0	104.8	139.7	4.0	26.7	31.5	42.2	63.5	88.9	4.0	20.3	23.9	PFA	4 x ⅝"	4 x ½"	6.4
2½"	1½"	140	73.0	104.8	139.7	4.0	26.7	31.5	48.3	73.0	98.4	4.0	21.9	25.5	PTFE	4 x ⅝"	4 x ½"	6.6
2½"	2"	140	73.0	104.8	139.7	4.0	26.7	31.5	60.3	92.1	120.7	4.0	23.5	27.6	PTFE	4 x ⅝"	4 x ⅝"	7.6
3"	1"	152	88.9	127.0	152.4	4.0	28.3	33.4	33.4	50.8	79.4	4.0	18.7	22.3	PFA	4 x ⅝"	4 x ½"	7.0
3"	1½"	152	88.9	127.0	152.4	4.0	28.3	33.4	48.3	73.0	98.4	4.0	21.9	25.5	PFA	4 x ⅝"	4 x ½"	7.9
3"	2"	152	88.9	127.0	152.4	3.0	27.3	32.4	60.3	92.1	120.7	3.0	22.5	26.6	PTFE	4 x ⅝"	4 x ⅝"	8.7
3"	2½"	152	88.9	127.0	152.4	3.0	27.3	32.4	73.0	104.8	139.7	3.0	25.7	30.5	PTFE	4 x ⅝"	4 x ⅝"	10.5
4"	2"	178	114.3	157.2	190.5	4.0	28.3	33.9	60.3	92.1	120.7	4.0	23.5	27.6	PFA	8 x ⅝"	4 x ⅝"	11.4
4"	2½"	178	114.3	157.2	190.5	4.5	28.8	34.4	73.0	104.8	139.7	4.5	27.2	32.0	PTFE	8 x ⅝"	4 x ⅝"	13.3
4"	3"	178	114.3	157.2	190.5	4.5	28.8	34.4	88.9	127.0	152.4	4.5	28.8	33.9	PTFE	8 x ⅝"	4 x ⅝"	14.3
5"	2½"	203	141.3	185.7	215.9	4.0	28.3	34.5	73.0	104.8	139.7	4.0	26.7	31.5	PFA	8 x ¾"	4 x ⅝"	15.6
5"	3"	203	141.3	185.7	215.9	4.0	28.3	34.5	88.9	127.0	152.4	4.0	28.3	33.4	PFA	8 x ¾"	4 x ⅝"	16.6
5"	4"	203	141.3	185.7	215.9	4.5	28.8	35.0	114.3	157.2	190.5	4.5	28.8	34.4	PTFE	8 x ¾"	8 x ⅝"	19.0

continued on the next page

Flanged Reducers concentric (Class 150)

NPS ₁	NPS ₂	L (mm)	d ₁₍₁₎ (mm)	d ₄₍₁₎ (mm)	K ₍₁₎ (mm)	s _{min (1)} (mm)	a ₁₍₁₎ (mm)	a ₂₍₁₎ (mm)	d ₁₍₂₎ (mm)	d ₄₍₂₎ (mm)	K ₍₂₎ (mm)	s _{min (2)} (mm)	a ₁₍₂₎ (mm)	a ₂₍₂₎ (mm)	Lining mate-ri- als	No. of bolts x thread (UNC)		Wt. (ca. kg/pc.)
																NPS ₁	NPS ₂	
6"	3"	229	168.3	215.9	241.3	4.0	29.9	36.5	88.9	127.0	152.4	4.0	28.3	33.4	PFA	8 x ¾"	4 x ⅝"	20.4
6"	4"	229	168.3	215.9	241.3	6.0	31.9	38.5	114.3	157.2	190.5	6.0	30.3	35.9	PTFE	8 x ¾"	8 x ⅝"	22.9
6"	5"	229	168.3	215.9	241.3	6.0	31.9	38.5	141.3	185.7	215.9	6.0	30.3	36.5	PTFE	8 x ¾"	8 x ¾"	24.0
8"	4"	279	219.1	269.9	298.5	6.0	35.0	42.8	114.3	157.2	190.5	6.0	30.3	35.9	PTFE	8 x ¾"	8 x ⅝"	46.3
8"	5"	279	219.1	269.9	298.5	6.0	35.0	42.8	141.3	185.7	215.9	6.0	30.3	36.5	PTFE	8 x ¾"	8 x ¾"	51.6
8"	6"	279	219.1	269.9	298.5	6.0	35.0	42.8	168.3	215.9	241.3	6.0	31.9	38.5	PTFE	8 x ¾"	8 x ¾"	39.2
10"	5"	305	273.0	323.8	362.0	6.0	36.6	45.5	141.3	185.7	215.9	6.0	30.3	36.5	PTFE	12 x ⅞"	8 x ¾"	62.1
10"	6"	305	273.0	323.8	362.0	6.0	36.6	45.5	168.3	215.9	241.3	6.0	31.9	38.5	PTFE	12 x ⅞"	8 x ¾"	70.4
10"	8"	305	273.0	323.8	362.0	6.0	36.6	45.5	219.1	269.9	298.5	6.0	35.0	42.8	PTFE	12 x ⅞"	8 x ¾"	60.1
12"	6"	356	323.8	381.0	431.8	6.0	38.2	48.1	168.3	215.9	241.3	6.0	31.9	38.5	PTFE	12 x ⅞"	8 x ¾"	89.1
12"	8"	356	323.8	381.0	431.8	6.0	38.2	48.1	219.1	269.9	298.5	6.0	35.0	42.8	PTFE	12 x ⅞"	8 x ¾"	105.6
12"	10"	356	323.8	381.0	431.8	6.0	38.2	48.1	273.0	323.8	362.0	6.0	36.6	45.5	PTFE	12 x ⅞"	12 x ⅞"	88.4
14"	8"	406	355.6	412.8	476.3	7.5	42.9	57.5	219.1	269.9	298.5	7.5	36.5	44.3	PTFE	12 x 1"	8 x ¾"	123.2
14"	10"	406	355.6	412.8	476.3	7.5	42.9	57.5	273.0	323.8	362.0	7.5	38.1	47.0	PTFE	12 x 1"	12 x ⅞"	136.1
14"	12"	406	355.6	412.8	476.3	7.5	42.9	57.5	323.8	381.0	431.8	7.5	39.7	49.6	PTFE	12 x 1"	12 x ⅞"	122.3
16"	10"	457	406.4	469.9	539.8	7.5	44.5	59.1	273.0	323.8	362.0	7.5	38.1	47.0	PTFE	16 x 1"	12 x ⅞"	157.4
16"	12"	457	406.4	469.9	539.8	7.5	44.5	59.1	323.8	381.0	431.8	7.5	39.7	49.6	PTFE	16 x 1"	12 x ⅞"	188.3
16"	14"	457	406.4	469.9	539.8	7.5	44.5	59.1	355.6	412.8	476.3	7.5	42.9	57.5	PTFE	16 x 1"	12 x 1"	157.9
18"	10"	483	457.0	533.4	577.9	8.0	48.1	62.7	273.0	323.8	362.0	8.0	38.6	47.5	PTFE	16 x 1 ⅛"	12 x ⅞"	170.2
18"	12"	483	457.0	533.4	577.9	8.0	48.1	62.7	323.8	381.0	431.8	8.0	40.2	50.1	PTFE	16 x 1 ⅛"	12 x ⅞"	201.3
18"	14"	483	457.0	533.4	577.9	8.0	48.1	62.7	355.6	412.8	476.3	8.0	43.4	58.0	PTFE	16 x 1 ⅛"	12 x 1"	171.0
20"	12"	508	508.0	584.2	635.0	8.0	51.3	65.9	323.8	381.0	431.8	8.0	40.2	50.1	PTFE	20 x 1 ⅛"	12 x ⅞"	224.1
20"	14"	508	508.0	584.2	635.0	8.0	51.3	65.9	355.6	412.8	476.3	8.0	43.4	58.0	PTFE	20 x 1 ⅛"	12 x 1"	255.3
20"	16"	508	508.0	584.2	635.0	8.0	51.3	65.9	406.4	469.9	539.8	8.0	45.0	59.6	PTFE	20 x 1 ⅛"	16 x 1"	211.3



The nominal pipe size combinations printed in bold are manufactured in two parts with flanges fix-fix or fix-loose in which the loose flange is generally on the NPS₁ side.

Different nominal pipe sizes and total lengths on request.

- L = Total length
 - d₁ = Outer diameter of the pipe
 - d₄ = Raised face diameter
 - K = Bolt circle diameter
 - s_{min} = Minimum flare thickness
 - a₁ = Minimum length with fixed flange and s_{min}
 - a₂ = Minimum length with loose flange and s_{min}
- Technical data valid for the pressure rating Class 150.
a₁ and a₂ depend on construction type and lining thickness.

NPS ₁	Lining thickness		Possible vacuum		
	standard	thick-walled	23° C	150° C	200° C
1"	●	●	☐	☐	☐
1½"	●	●	☐	☐	☐
2"	●	●	☐	☐	☐
3"	●	●	☐	☐	☐
4"	●	●	☐	☐	☐
6"	●	●	☐	☐	☐
8"	●	●	☐	☐	☐
10"	●	●	☐	☐	☐
12"	●	●	☐	☐	☐

Bitte Rücksprache

Vacuum resistance:
 = full vacuum
 = limited vacuum
 = no vacuum
 Please refer to the next higher nominal pipe size if your nominal pipe size is not listed.

Flanged Reducers excentric (Class 150)

In case of horizontal installation, excentric Flanged Reducers enable the complete draining of pipe sections. Depending on the nominal width, the reducers are lined with PTFE, PFA or PP.

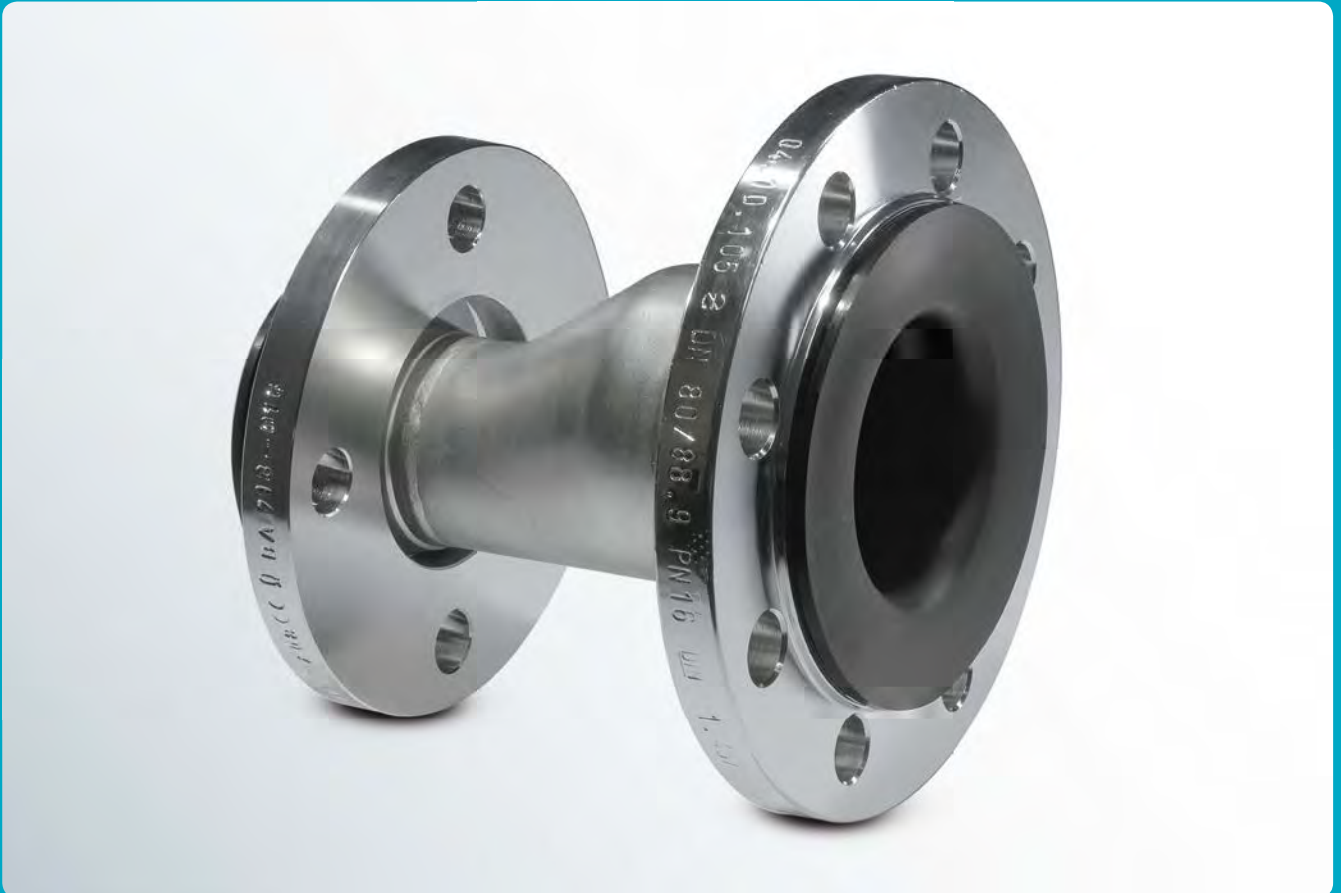

Flanged Reducers excentric (Class 150)

Materials:

- carbon steel
- stainless steel

Lining materials:

- PTFE (virgin or conductive)
- PFA (virgin or conductive)
- PP

Flanges:

- fix-fix
- fix-loose
- loose-loose

Other pressure rating:

- Class 150

Special features:

- earthing stud/ lug
- vent hole extension

Optional extras:

- final painting
- non-destructive testing

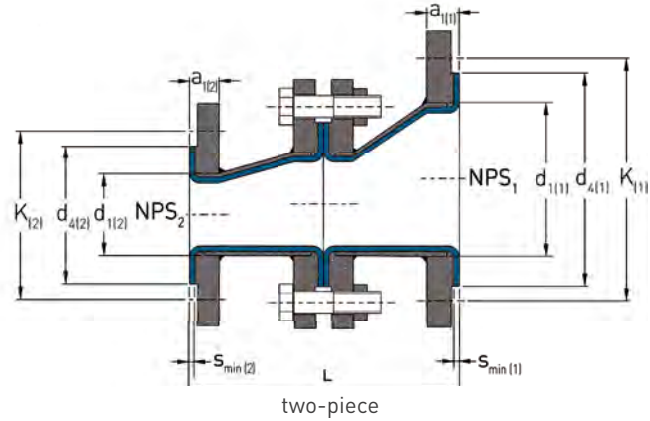
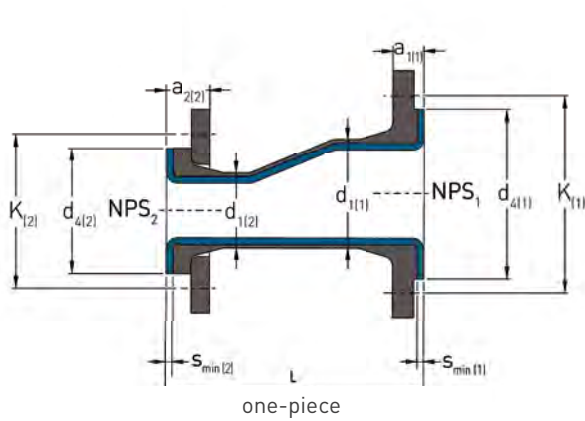

NPS ₁	NPS ₂	L (mm)	d ₁₍₁₎ (mm)	d ₄₍₁₎ (mm)	K ₁₍₁₎ (mm)	s _{min(1)} (mm)	a ₁₍₁₎ (mm)	a ₂₍₁₎ (mm)	d ₁₍₂₎ (mm)	d ₄₍₂₎ (mm)	K ₂₍₂₎ (mm)	s _{min(2)} (mm)	a ₁₍₂₎ (mm)	a ₂₍₂₎ (mm)	Lining materials	No. of bolts x thread [UNC]		Wt. [ca. kg/pc.]
																NPS ₁	NPS ₂	
¾"	½"	114	26.7	42.9	69.9	3.0	16.2	19.7	26.7	34.9	60.3	3.0	14.6	18.2	PTFE	4 x ½"	4 x ½"	1.5
1"	½"	114	33.4	50.8	79.4	3.0	17.7	21.3	26.7	34.9	60.3	3.0	14.6	18.2	PTFE	4 x ½"	4 x ½"	1.9
1"	¾"	114	33.4	50.8	79.4	3.0	17.7	21.3	26.7	42.9	69.9	3.0	16.2	19.7	PTFE	4 x ½"	4 x ½"	2.3
1¼"	¾"	114	42.2	63.5	88.9	3.0	19.3	22.9	26.7	42.9	69.9	3.0	16.2	19.7	PTFE	4 x ½"	4 x ½"	2.7
1¼"	1"	114	42.2	63.5	88.9	3.0	19.3	22.9	33.4	50.8	79.4	3.0	17.7	21.3	PTFE	4 x ½"	4 x ½"	3.1
1½"	¾"	114	48.3	73.0	98.4	4.0	21.9	25.5	26.7	42.9	69.9	4.0	17.2	20.7	PFA	4 x ½"	4 x ½"	3.0
1½"	1"	114	48.3	73.0	98.4	3.0	20.9	24.5	33.4	50.8	79.4	3.0	17.7	21.3	PTFE	4 x ½"	4 x ½"	3.3
1½"	1¼"	114	48.3	73.0	98.4	3.0	20.9	24.5	42.2	63.5	88.9	3.0	19.3	22.9	PTFE	4 x ½"	4 x ½"	3.7
2"	1"	127	60.3	92.1	120.7	4.0	23.5	27.6	33.4	50.8	79.4	4.0	18.7	22.3	PFA	4 x ⅝"	4 x ½"	4.5
2"	1¼"	127	60.3	92.1	120.7	3.0	22.5	26.6	42.2	63.5	88.9	3.0	19.3	22.9	PTFE	4 x ⅝"	4 x ½"	5.0
2"	1½"	127	60.3	92.1	120.7	3.0	22.5	26.6	48.3	73.0	98.4	3.0	20.9	24.5	PTFE	4 x ⅝"	4 x ½"	5.1
2½"	1¼"	140	73.0	104.8	139.7	4.0	26.7	31.5	42.2	63.5	88.9	4.0	20.3	23.9	PFA	4 x ⅝"	4 x ½"	6.3
2½"	1½"	140	73.0	104.8	139.7	4.0	26.7	31.5	48.3	73.0	98.4	4.0	21.9	25.5	PTFE	4 x ⅝"	4 x ½"	6.6
2½"	2"	140	73.0	104.8	139.7	4.0	26.7	31.5	60.3	92.1	120.7	4.0	23.5	27.6	PTFE	4 x ⅝"	4 x ⅝"	7.6
3"	1"	152	88.9	127.0	152.4	4.0	28.3	33.4	33.4	50.8	79.4	4.0	18.7	22.3	PFA	4 x ⅝"	4 x ½"	7.0
3"	1½"	152	88.9	127.0	152.4	4.0	28.3	33.4	48.3	73.0	98.4	4.0	21.9	25.5	PFA	4 x ⅝"	4 x ½"	7.8
3"	2"	152	88.9	127.0	152.4	3.0	27.3	32.4	60.3	92.1	120.7	3.0	22.5	26.6	PTFE	4 x ⅝"	4 x ⅝"	8.7
3"	2½"	152	88.9	127.0	152.4	3.0	27.3	32.4	73.0	104.8	139.7	3.0	25.7	30.5	PTFE	4 x ⅝"	4 x ⅝"	10.5
4"	2"	178	114.3	157.2	190.5	4.0	28.3	33.9	60.3	92.1	120.7	4.0	23.5	27.6	PFA	8 x ⅝"	4 x ⅝"	11.3
4"	2½"	178	114.3	157.2	190.5	4.5	28.8	34.4	73.0	104.8	139.7	4.5	27.2	32.0	PTFE	8 x ⅝"	4 x ⅝"	13.2
4"	3"	178	114.3	157.2	190.5	4.5	28.8	34.4	88.9	127.0	152.4	4.5	28.8	33.9	PTFE	8 x ⅝"	4 x ⅝"	14.2
5"	2½"	203	141.3	185.7	215.9	4.0	28.3	34.5	73.0	104.8	139.7	4.0	26.7	31.5	PFA	8 x ¾"	4 x ⅝"	15.5
5"	3"	203	141.3	185.7	215.9	4.0	28.3	34.5	88.9	127.0	152.4	4.0	28.3	33.4	PFA	8 x ¾"	4 x ⅝"	16.5
5"	4"	203	141.3	185.7	215.9	4.5	28.8	35.0	114.3	157.2	190.5	4.5	28.8	34.4	PTFE	8 x ¾"	8 x ⅝"	18.9

continued on the next page

Flanged Reducers excentric (Class 150)

NPS ₁	NPS ₂	L (mm)	d ₁₍₁₎ (mm)	d ₄₍₁₎ (mm)	K ₁₍₁₎ (mm)	s _{min(1)} (mm)	a ₁₍₁₎ (mm)	a ₂₍₁₎ (mm)	d ₁₍₂₎ (mm)	d ₄₍₂₎ (mm)	K ₁₍₂₎ (mm)	s _{min(2)} (mm)	a ₁₍₂₎ (mm)	a ₂₍₂₎ (mm)	Lining materials	No. of bolts x thread (UNC)		Wt. (ca. kg/pc.)
																NPS ₁	NPS ₂	
6"	3"	229	168.3	215.9	241.3	4.0	29.9	36.5	88.9	127.0	152.4	4.0	28.3	33.4	PFA	8 x 3/4"	4 x 5/8"	20.2
6"	4"	229	168.3	215.9	241.3	6.0	31.9	38.5	114.3	157.2	190.5	6.0	30.3	35.9	PTFE	8 x 3/4"	8 x 5/8"	22.7
6"	5"	229	168.3	215.9	241.3	6.0	31.9	38.5	141.3	185.7	215.9	6.0	30.3	36.5	PTFE	8 x 3/4"	8 x 3/4"	23.9
8"	4"	279	219.1	269.9	298.5	6.0	35.0	42.8	114.3	157.2	190.5	6.0	30.3	35.9	PTFE	8 x 3/4"	8 x 5/8"	46.0
8"	5"	279	219.1	269.9	298.5	6.0	35.0	42.8	141.3	185.7	215.9	6.0	30.3	36.5	PTFE	8 x 3/4"	8 x 3/4"	51.3
8"	6"	279	219.1	269.9	298.5	6.0	35.0	42.8	168.3	215.9	241.3	6.0	31.9	38.5	PTFE	8 x 3/4"	8 x 3/4"	38.9
10"	5"	305	273.0	323.8	362.0	6.0	36.6	45.5	141.3	185.7	215.9	6.0	30.3	36.5	PTFE	12 x 7/8"	8 x 3/4"	61.6
10"	6"	305	273.0	323.8	362.0	6.0	36.6	45.5	168.3	215.9	241.3	6.0	31.9	38.5	PTFE	12 x 7/8"	8 x 3/4"	69.8
10"	8"	305	273.0	323.8	362.0	6.0	36.6	45.5	219.1	269.9	298.5	6.0	35.0	42.8	PTFE	12 x 7/8"	8 x 3/4"	59.4
12"	6"	356	323.8	381.0	431.8	6.0	38.2	48.1	168.3	215.9	241.3	6.0	31.9	38.5	PTFE	12 x 7/8"	8 x 3/4"	88.4
12"	8"	356	323.8	381.0	431.8	6.0	38.2	48.1	219.1	269.9	298.5	6.0	35.0	42.8	PTFE	12 x 7/8"	8 x 3/4"	104.8
12"	10"	356	323.8	381.0	431.8	6.0	38.2	48.1	273.0	323.8	362.0	6.0	36.6	45.5	PTFE	12 x 7/8"	12 x 7/8"	87.4
14"	8"	406	355.6	412.8	476.3	7.5	42.9	57.5	219.1	269.9	298.5	7.5	36.5	44.3	PTFE	12 x 1"	8 x 3/4"	122.1
14"	10"	406	355.6	412.8	476.3	7.5	42.9	57.5	273.0	323.8	362.0	7.5	38.1	47.0	PTFE	12 x 1"	12 x 7/8"	134.9
14"	12"	406	355.6	412.8	476.3	7.5	42.9	57.5	323.8	381.0	431.8	7.5	39.7	49.6	PTFE	12 x 1"	12 x 7/8"	121.0
16"	10"	457	406.4	469.9	539.8	7.5	44.5	59.1	273.0	323.8	362.0	7.5	38.1	47.0	PTFE	16 x 1"	12 x 7/8"	156.0
16"	12"	457	406.4	469.9	539.8	7.5	44.5	59.1	323.8	381.0	431.8	7.5	39.7	49.6	PTFE	16 x 1"	12 x 7/8"	186.8
16"	14"	457	406.4	469.9	539.8	7.5	44.5	59.1	355.6	412.8	476.3	7.5	42.9	57.5	PTFE	16 x 1"	12 x 1"	156.3
18"	10"	483	457.0	533.4	577.9	8.0	48.1	62.7	273.0	323.8	362.0	8.0	38.6	47.5	PTFE	16 x 1 1/8"	12 x 7/8"	168.5
18"	12"	483	457.0	533.4	577.9	8.0	48.1	62.7	323.8	381.0	431.8	8.0	40.2	50.1	PTFE	16 x 1 1/8"	12 x 7/8"	199.5
18"	14"	483	457.0	533.4	577.9	8.0	48.1	62.7	355.6	412.8	476.3	8.0	43.4	58.0	PTFE	16 x 1 1/8"	12 x 1"	169.1
20"	12"	508	508.0	584.2	635.0	8.0	51.3	65.9	323.8	381.0	431.8	8.0	40.2	50.1	PTFE	20 x 1 1/8"	12 x 7/8"	222.1
20"	14"	508	508.0	584.2	635.0	8.0	51.3	65.9	355.6	412.8	476.3	8.0	43.4	58.0	PTFE	20 x 1 1/8"	12 x 1"	253.1
20"	16"	508	508.0	584.2	635.0	8.0	51.3	65.9	406.4	469.9	539.8	8.0	45.0	59.6	PTFE	20 x 1 1/8"	16 x 1"	209.0



The nominal pipe size combinations printed in bold are manufactured in two parts with flanges fix-fix or fix-loose in which the loose flange is generally on the NPS₁ side.

Different nominal pipe sizes and total lengths on request.

- L = Total length
 - d₁ = Outer diameter of the pipe
 - d₄ = Raised face diameter
 - K = Bolt circle diameter
 - s_{min} = Minimum flare thickness
 - a₁ = Minimum length with fixed flange and s_{min}
 - a₂ = Minimum length with loose flange and s_{min}
- Technical data valid for the pressure rating Class 150.
a₁ and a₂ depend on construction type and lining thickness.

NPS ₁	Lining thickness		Possible vacuum		
	standard	thick-walled	23°C	150°C	200°C
1"	●	●	☐	☐	☐
1 1/2"	●	●	☐	☐	☐
2"	●	●	☐	☐	☐
3"	●	●	☐	☐	☐
4"	●	●	☐	☐	☐
6"	●	●	☐	☐	☐
8"	●	●	☐	☐	☐
10"	●	●	☐	☐	☐
12"	●	●	☐	☐	☐

Please confer with us.

Vacuum resistance:
 = full vacuum
 = limited vacuum
 = no vacuum
 Please refer to the next higher nominal pipe size if your nominal pipe size is not listed.



Valves



Ball Check Valves (Class 150)

Ball Check Valves for horizontal or vertical installation reliably prevent the reverse flow of working medium. At the same time, they offer the least possible resistance in the direction of flow.



Ball Check Valves (Class 150)

Materials:

- carbon steel
- stainless steel

Lining material:

- PTFE (virgin or conductive)

Other pressure rating:

- Class 300

Special features:

- earthing stud/lug
- vent hole extension

Optional extras:

- final painting
- non-destructive testing

Form A
vertical

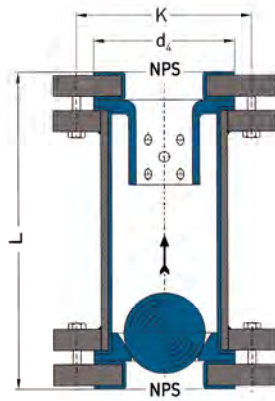

Form B
horizontal

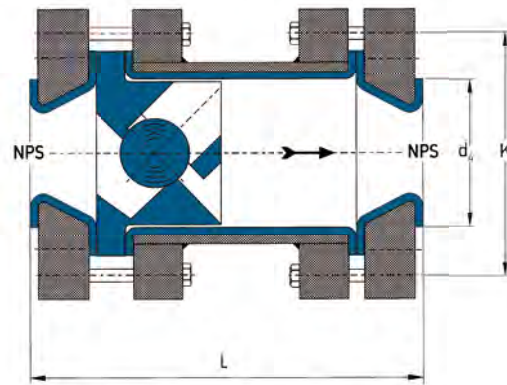

NPS	L (mm)		d ₄ (mm)	K (mm)	No. of bolts x thread (UNC)	Weights (ca. kg/piece)	
	Form A	Form B				Form A	Form B
1"	178	178	50.8	79.4	4 x 1/2"	4.7	17.3
1 1/4"	190	190	63.5	88.9	4 x 1/2"	6.8	25.1
1 1/2"	204	204	73.0	98.4	4 x 1/2"	8.7	32.0
2"	228	228	92.1	120.7	4 x 5/8"	10.3	37.9
2 1/2"	254	254	104.8	139.7	4 x 5/8"	17.3	63.9
3"	280	280	127.0	152.4	4 x 5/8"	19.5	72.1
4"	330	330	157.2	190.5	8 x 5/8"	23.4	86.7
5"	380	380	185.7	215.9	8 x 3/4"	34.0	125.6
6"	406	406	215.9	241.3	8 x 3/4"	45.7	168.8
8"	458	458	269.9	298.5	8 x 3/4"	70.5	260.8

Different nominal pipe sizes
and total lengths on request.

L = Total length

d₄ = Raised face diameter

K = Bolt circle diameter

Technical data valid for the
pressure rating Class 150.

NPS	Lining thickness		Possible vacuum		
	standard	thick-walled	23°C	150°C	200°C
1"	●	●	▬	▬	▬
1 1/2"	●	●	▬	▬	▬
2"	●	●	▬	▬	▬
3"	●	●	▬	▬	▬
4"	●	●	▬	▬	▬
6"	●	●	▬	▬	▬
8"	●	●	▬	▬	▬

Vacuum resistance:

▬ = full vacuum

▬ = limited vacuum

▬ = no vacuum

Please refer to the next
higher nominal pipe size
if your nominal pipe size
is not listed.

Bull's Eye Sight Indicators (Class 150)

Our Bull's Eye Sight Indicators – manufactured with high-quality borosilicate glasses – offer you the right view at any time.



Bull's Eye Sight Indicators (Class 150)

Materials:

- carbon steel
- stainless steel

Lining materials:

- up to nominal pipe size NPS 4": PFA (virgin or conductive)
- from nominal pipe size NPS 5": PTFE (virgin or conductive)
- up to nominal pipe size NPS 12": PP

Flange:

- fix-fix
- fix-loose
- loose-loose

Other pressure rating:

- Class 300

Special features:

- earthing stud/lug
- vent hole extension
- flange stopper

Optional extras:

- final painting
- non-destructive testing

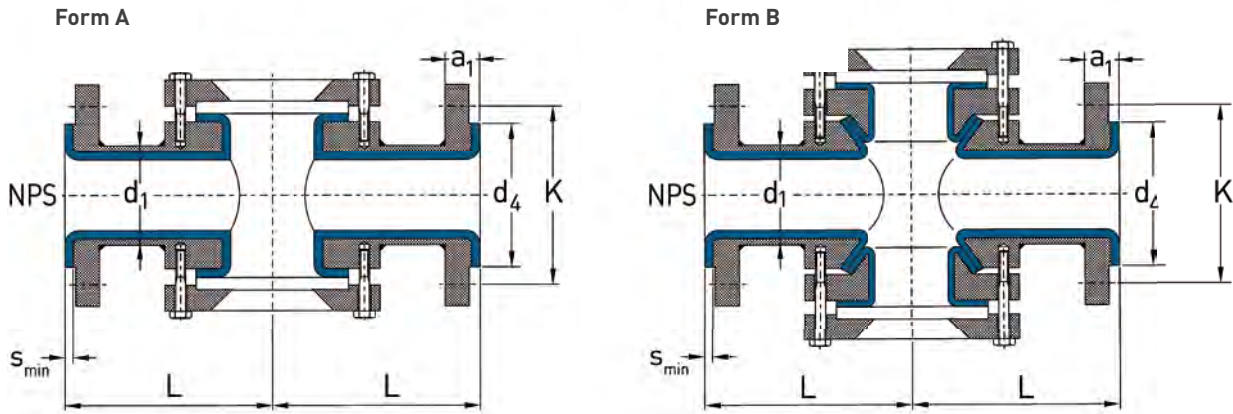

NPS	L (mm)	Form	d ₁ (mm)	d ₄ (mm)	K (mm)	s _{min} (mm)	a ₁ (mm)	a ₂ (mm)	No. of bolts x thread (UNC)	Weights (ca. kg/ piece)
1"	89	A	33.4	50.8	79.4	4.0	18.7	22.3	4 x 1/2"	6.1
1 1/4"	95	A	42.2	63.5	88.9	4.0	20.3	23.9	4 x 1/2"	9.6
1 1/2"	102	A	48.3	73.0	98.4	4.0	21.9	25.5	4 x 1/2"	11.3
2"	114	A	60.3	92.1	120.7	4.0	23.5	27.6	4 x 5/8"	15.5
2 1/2"	127	A	73.0	104.8	139.7	4.0	26.7	31.5	4 x 5/8"	20.7
3"	140	A	88.9	127.0	152.4	4.0	28.3	33.4	4 x 5/8"	24.4
4"	165	A	114.3	157.2	190.5	4.0	28.3	33.9	8 x 5/8"	32.2
5"	190	B	141.3	185.7	215.9	5.0	29.3	35.5	8 x 3/4"	62.7
6"	203	B	168.3	215.9	241.3	7.0	31.9	38.5	8 x 3/4"	82.5
8"	229	B	219.1	269.9	298.5	6.0	35.0	42.8	8 x 3/4"	118.2
10"	280	B	273.0	323.8	362.0	7.5	38.1	47.0	12 x 7/8"	164.0
12"	305	B	323.8	381.0	431.8	7.5	39.7	49.6	12 x 7/8"	213.1
14"	356	B	355.6	412.8	476.3	10.0	45.4	60.0	12 x 1"	296.3
16"	381	B	406.4	469.9	539.8	7.0	44.0	58.6	16 x 1"	393.7

Different nominal pipe sizes and total lengths on request.

L = Total length
d₁ = Outer diameter of the pipe
d₄ = Raised face diameter
K = Bolt circle diameter
s_{min} = Minimum flare thickness
a₁ = Mindestlänge bei Minimum length with fixed flange and s_{min}
a₂ = Minimum length with loose flange and s_{min}
Technical data valid for the pressure rating Class 150.
a₁ and a₂ depend on construction type and lining thickness.

NPS	Lining thickness		Possible vacuum		
	standard	thick-walled	23° C	150° C	200° C
1"	●	●	☐	☐	☐
1 1/2"	●	●	☐	☐	☐
2"	●	●	☐	☐	☐
3"	●	●	☐	☐	☐
4"	●	●	☐	☐	☐

NPS	Lining thickness		Possible vacuum		
	standard	thick-walled	23° C	150° C	200° C
6"	●	●	☐	☐	☐
8"	●	●	☐	☐	☐
10"	●	●	☐	☐	☐
12"	●	●	☐	☐	☐

Vacuum resistance:

- ☐ = full vacuum
- ☐ = limited vacuum
- ☐ = no vacuum

Please refer to the next higher nominal pipe size if your nominal pipe size is not listed.



Blind Flanges

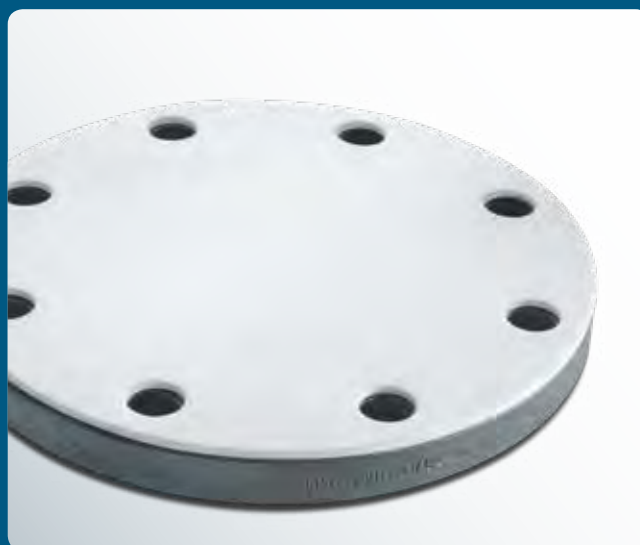

Blind Flanges (Class 150)

Any piping needs cleaning connections and also additional connections. Blind flanges close these connections during regular operation.

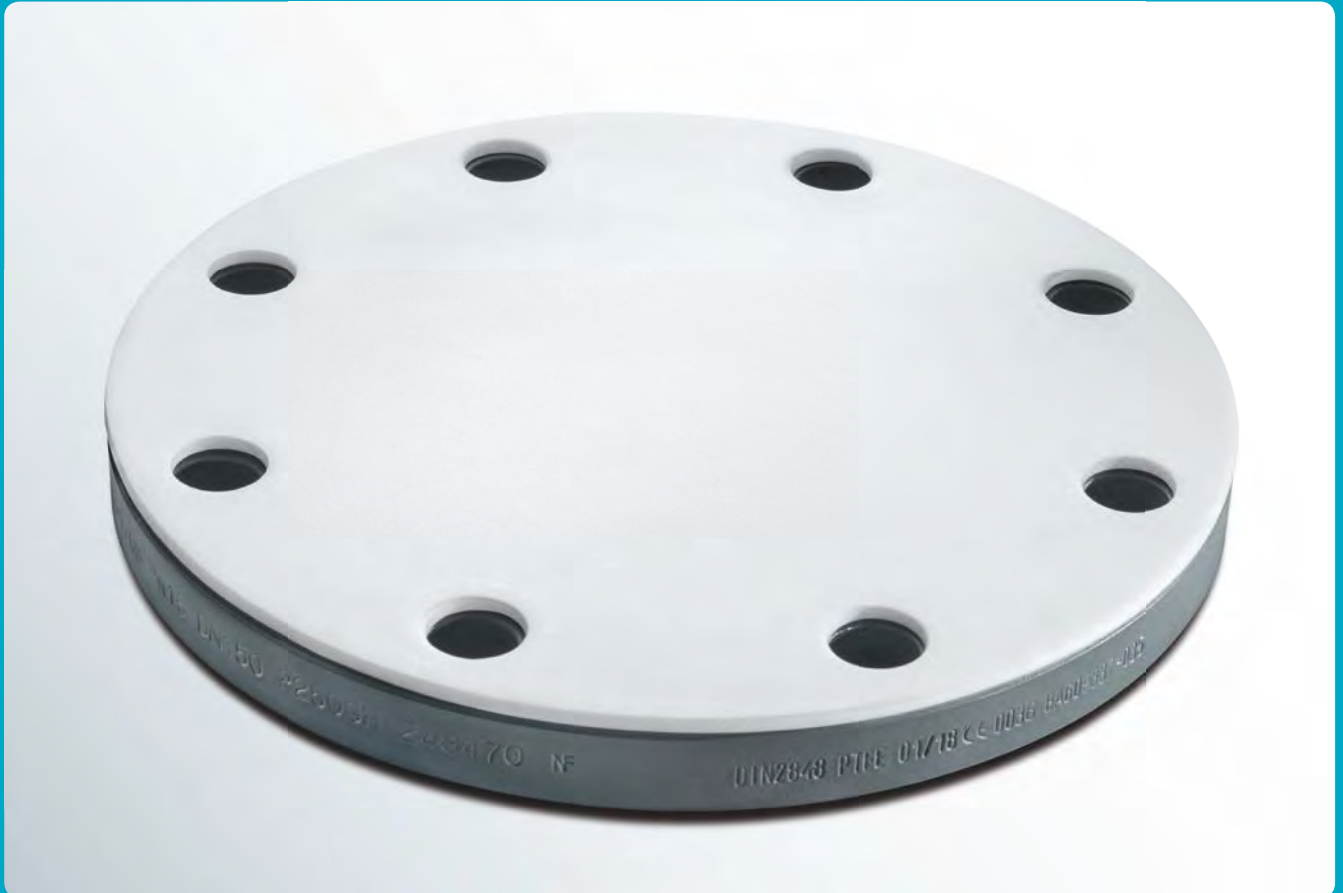

Blind Flanges (Class 150)

Materials:

- carbon steel
- stainless steel

Lining materials:

- PTFE (virgin or conductive)
- PP (up to nominal pipe size NPS 12")

Other pressure rating:

- Class 300

Special features:

- earthing stud/lug

Optional extras:

- final painting

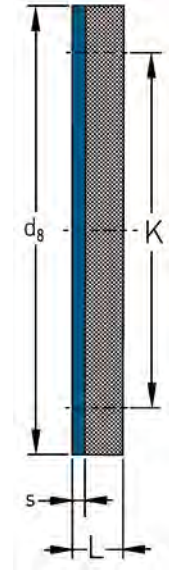

NPS	L (mm)	d _g (mm)	K (mm)	s (mm)	No. of bolts x thread (UNC)	Weights (ca. kg/piece)
1/2"	13.6	90	60.3	4.0	4 x 1/2"	0.5
3/4"	15.2	100	69.9	4.0	4 x 1/2"	0.7
1"	16.7	110	79.4	4.0	4 x 1/2"	1.0
1 1/4"	18.3	115	88.9	4.0	4 x 1/2"	1.2
1 1/2"	19.9	125	98.4	4.0	4 x 1/2"	1.5
2"	21.5	150	120.7	4.0	4 x 5/8"	2.4
2 1/2"	24.7	180	139.7	4.0	4 x 5/8"	4.2
3"	26.3	190	152.4	4.0	4 x 5/8"	5.0
4"	27.3	230	190.5	5.0	8 x 5/8"	7.3
5"	27.3	255	215.9	5.0	8 x 3/4"	8.9
6"	28.9	280	241.3	5.0	8 x 3/4"	11.6
8"	32.0	345	298.5	5.0	8 x 3/4"	20.2
10"	33.6	405	362.0	5.0	12 x 7/8"	28.9
12"	35.2	485	431.8	5.0	12 x 7/8"	44.3
14"	38.4	535	476.3	5.0	12 x 1"	59.4
16"	40.0	595	539.8	5.0	16 x 1"	76.6
18"	43.1	635	577.9	5.0	16 x 1 1/8"	94.3
20"	46.3	700	635.0	5.0	20 x 1 1/8"	123.8

Different nominal pipe sizes, total lengths and other construction types on request.

L = Total length

d_g = Outer diameter

K = Bolt circle diameter

s = Lining thickness

Technical data valid for the pressure rating Class 150.

L depend on construction type and lining thickness.

NPS	Lining thickness		Possible vacuum		
	standard	thick-walled	23° C	150° C	200° C
1"	●	●	▬	▬	▬
1 1/2"	●	●	▬	▬	▬
2"	●	●	▬	▬	▬
3"	●	●	▬	▬	▬
4"	●	●	▬	▬	▬
6"	●	●	▬	▬	▬
8"	●	●	▬	▬	▬
10"	●	●	▬	▬	▬
12"	●	●	▬	▬	▬

Vacuum resistance:

▬ = full vacuum

▬ = limited vacuum

▬ = no vacuum

Please refer to the next higher nominal pipe size if your nominal pipe size is not listed.

Expansion Joints



PTFE Expansion Joints, 1 convolute (Class 150)

Our PTFE Expansion Joints are highly flexible and provide compensation of vibrations and heat-induced expansion in your production line. PTFE Expansion Joints with 1 convolute allow high working pressures.



PTFE Expansion Joints, 1 convolute (Class 150) - BAUM-Flex

Designs:

- up to nominal pipe size DN 100 with two ears
- from nominal pipe size DN 125 with three ears
- up to nominal pipe size DN 65 with threaded holes
- from nominal pipe size DN 80 with through holes

Flange materials:

- carbon steel
- up to nominal pipe size DN 300 chromated
- from DN 350 primed
- stainless steel

Lining material:

- PTFE (virgin or conductive)

Flanges:

- loose-loose

Other pressure ratings:

- on request

Special features:

- tie rod

Optional extras:

- final painting
- limit sleeve
- earthing stud/lug

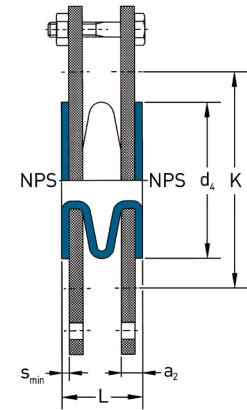

NPS >20" on request	L (mm)	Stroke ± (mm)	Lateral offset ± (mm)	Angular offset ± max. (°)	d ₄ (mm)	K (mm)	s _{min} (mm)	a ₂ (mm)	No. of bolts x thread (UNC)	Weights (ca. kg/pc.)
½"	40	5	2	2	45	65	3,0	13,0	4 x ½"	1,3
¾"	40	5	2	2	58	75	3,0	13,0	4 x ½"	1,6
1"	40	5	2	2	68	85	3,0	13,0	4 x ½"	1,7
1¼"	40	5	2	2	78	100	3,0	13,0	4 x ½"	2,4
1½"	40	5	2	2	88	110	3,0	13,0	4 x ½"	2,8
2"	48	6	2	2	102	125	4,0	16,0	4 x ⅝"	3,9
2½"	54	7	3	3	122	145	4,0	16,0	4 x ⅝"	4,9
3"	60	7	3	3	138	160	4,0	16,0	4 x ⅝"	5,4
4"	64	7	3	4	158	180	5,0	20,0	8 x ⅝"	7,5
5"	70	7	4	4	188	210	4,5	19,5	8 x ¾"	9,9
6"	75	10	4	4	212	240	5,0	23,0	8 x ¾"	14,4
8"	85	10	4	3	268	295	7,5	27,5	8 x ¾"	24,5
10"	93	10	5	3	320	350	7,5	29,5	12 x ⅞"	29,5
12"	100	12	5	3	370	400	7,5	32,5	12 x ⅞"	51,0
14"	103	12	5	2	430	460	7,5	37,5	12 x 1"	67,7
16"	103	12	5	2	482	515	7,0	37,0	16 x 1"	81,7
20"	103	12	5	2	585	620	7,5	37,5	20 x 1⅞"	94,3

NPS	Overpressure resistance (10 ⁵ Pa) at				Vacuum resistance (10 ⁵ Pa) at		
	23°C	100°C	150°C	200°C	23°C	100°C	150°C
½"	10,0	9,1	7,3	5,9	-1,00	-1,00	-1,00
¾"	10,0	9,1	7,3	5,9	-1,00	-1,00	-1,00
1"	10,0	9,1	7,3	5,9	-1,00	-1,00	-1,00
1¼"	10,0	9,1	7,3	5,9	-1,00	-1,00	-1,00
1½"	10,0	9,1	7,3	5,9	-1,00	-1,00	-1,00
2"	10,0	9,1	7,3	5,9	-1,00	-1,00	-1,00
2½"	10,0	7,8	6,3	5,1	-1,00	-1,00	-1,00
3"	10,0	7,8	6,3	5,1	-1,00	-1,00	-1,00
4"	10,0	7,8	6,3	5,1	-1,00	-1,00	-1,00
5"	10,0	6,1	4,9	4,0	-1,00	-1,00	-1,00
6"	10,0	6,1	4,9	4,0	-1,00	-1,00	-1,00
8"	7,2	4,2	3,4	2,7	-1,00	-1,00	-1,00
10"	7,2	4,2	3,4	2,7	-1,00	-1,00	-0,83
12"	7,2	4,2	3,4	2,7	-1,00	-1,00	-0,70

Different nominal pipe sizes and total lengths on request.

L = Total length

d₄ = Raised face diameter

K = Bolt circle diameter

s_{min} = Minimum liner thickness

a₂ = Minimum length with loose flange and s_{min}

Technical data valid for the pressure rating Class 150.
a₂ depends on construction type and lining thickness.

The overpressure resistance is only valid at neutral position of the PTFE Expansion Joint with limit bolts in place. The types of travel stroke, lateral offset and angular offset are maximum allowable movements in only one direction. For superpositioned movement the single types of travel need to be limited. The figures stated are average and apply to room temperature.

PTFE Expansion Joints, 2 convolutes (Class 150)

Our PTFE Expansion Joints are highly flexible and provide compensation of vibrations and heat-induced expansion in your production line. The possible absorption of movement is increased by a higher number of convolutes.



PTFE Expansion Joints, 2 convolutes (Class 150) – Baum-Flex

Designs:

- up to nominal pipe size DN 100 with two ears
- from nominal pipe size DN 125 with three ears
- up to nominal pipe size DN 65 with threaded holes
- from nominal pipe size DN 80 with through holes

Flange materials:

- carbon steel
- up to nominal pipe size DN 300 chromated
- from DN 350 primed
- stainless steel

Lining material:

- PTFE (virgin or conductive)

Flanges:

- loose-loose

Other pressure ratings:

- on request

Special features:

- tie rod

Optional extras:

- final painting
- limit sleeve
- earthing stud/lug

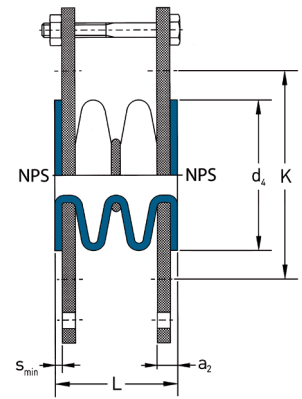

NPS >20" on request	L (mm)	Stroke ± (mm)	Lateral offset ± (mm)	Angular offset ± max.(°)	d ₄ (mm)	K (mm)	s _{min} (mm)	a ₂ (mm)	No. of bolts x thread (UNC)	Weights (ca. kg/pc.)
1/2"	54	6	3	4	45	65	3,0	13,0	4 x 1/2"	1,3
3/4"	54	6	3	4	58	75	3,0	13,0	4 x 1/2"	1,6
1"	54	6	3	4	68	85	3,0	13,0	4 x 1/2"	1,8
1 1/4"	56	6	3	4	78	100	3,0	13,0	4 x 1/2"	2,5
1 1/2"	56	6	3	4	88	110	3,0	13,0	4 x 1/2"	2,9
2"	68	10	5	5	102	125	4,0	16,0	4 x 5/8"	4,0
2 1/2"	78	12	5	5	122	145	4,0	16,0	4 x 5/8"	5,0
3"	88	15	5	6	138	160	4,0	16,0	4 x 5/8"	5,7
4"	88	15	8	6	158	180	5,0	20,0	8 x 5/8"	7,8
5"	95	15	8	5	188	210	4,5	19,5	8 x 3/4"	10,4
6"	105	15	8	5	212	240	5,0	23,0	8 x 3/4"	14,8
8"	110	15	10	5	268	295	7,5	27,5	8 x 3/4"	24,6
10"	128	20	10	4	320	350	7,5	29,5	12 x 7/8"	31,7
12"	140	20	10	4	370	400	7,5	32,5	12 x 7/8"	54,6
14"	145	20	10	4	430	460	7,5	37,5	12 x 1"	71,0
16"	145	20	12	3	482	515	7,0	37,0	16 x 1"	85,3
20"	145	30	12	3	585	620	7,5	37,5	20 x 1 1/8"	98,3

NPS	Overpressure resistance (10 ⁵ Pa) at				Vacuum resistance (10 ⁵ Pa) at		
	23°C	100°C	150°C	200°C	23°C	100°C	150°C
1/2"	10,0	8,8	7,0	5,7	-1,00	-1,00	-1,00
3/4"	10,0	8,8	7,0	5,7	-1,00	-1,00	-1,00
1"	10,0	8,8	7,0	5,7	-1,00	-1,00	-1,00
1 1/4"	10,0	8,8	7,0	5,7	-1,00	-1,00	-1,00
1 1/2"	10,0	8,8	7,0	5,7	-1,00	-1,00	-1,00
2"	10,0	8,8	7,0	5,7	-1,00	-1,00	-1,00
2 1/2"	10,0	7,6	6,0	4,9	-1,00	-1,00	-1,00
3"	10,0	7,6	6,0	4,9	-1,00	-1,00	-1,00
4"	10,0	7,6	6,0	4,9	-1,00	-1,00	-1,00
5"	10,0	5,9	4,7	3,8	-1,00	-1,00	-1,00
6"	10,0	5,9	4,7	3,8	-1,00	-1,00	-1,00
8"	6,9	4,1	3,2	2,6	-1,00	-1,00	-1,00
10"	6,9	4,1	3,2	2,6	-1,00	-1,00	-0,76
12"	6,9	4,1	3,2	2,6	-1,00	-0,86	-0,66

Different nominal pipe sizes and total lengths on request.

L = Total length

d₄ = Raised face diameter

K = Bolt circle diameter

s_{min} = Minimum liner thickness

a₂ = Minimum length with loose flange and s_{min}

Technical data valid for the pressure rating Class 150. a₂ depends on construction type and lining thickness.

The overpressure resistance is only valid at neutral position of the PTFE Expansion Joint with limit bolts in place. The types of travel stroke, lateral offset and angular offset are maximum allowable movements in only one direction. For superpositioned movement the single types of travel need to be limited. The figures stated are average and apply to room temperature.

PTFE Expansion Joints, 3 convolutes (Class 150)

Our PTFE Expansion Joints are highly flexible and provide compensation of vibrations and heat-induced expansion in your production line. PTFE Expansion Joints with 3 convolutes are the standard solution for most of the applications.

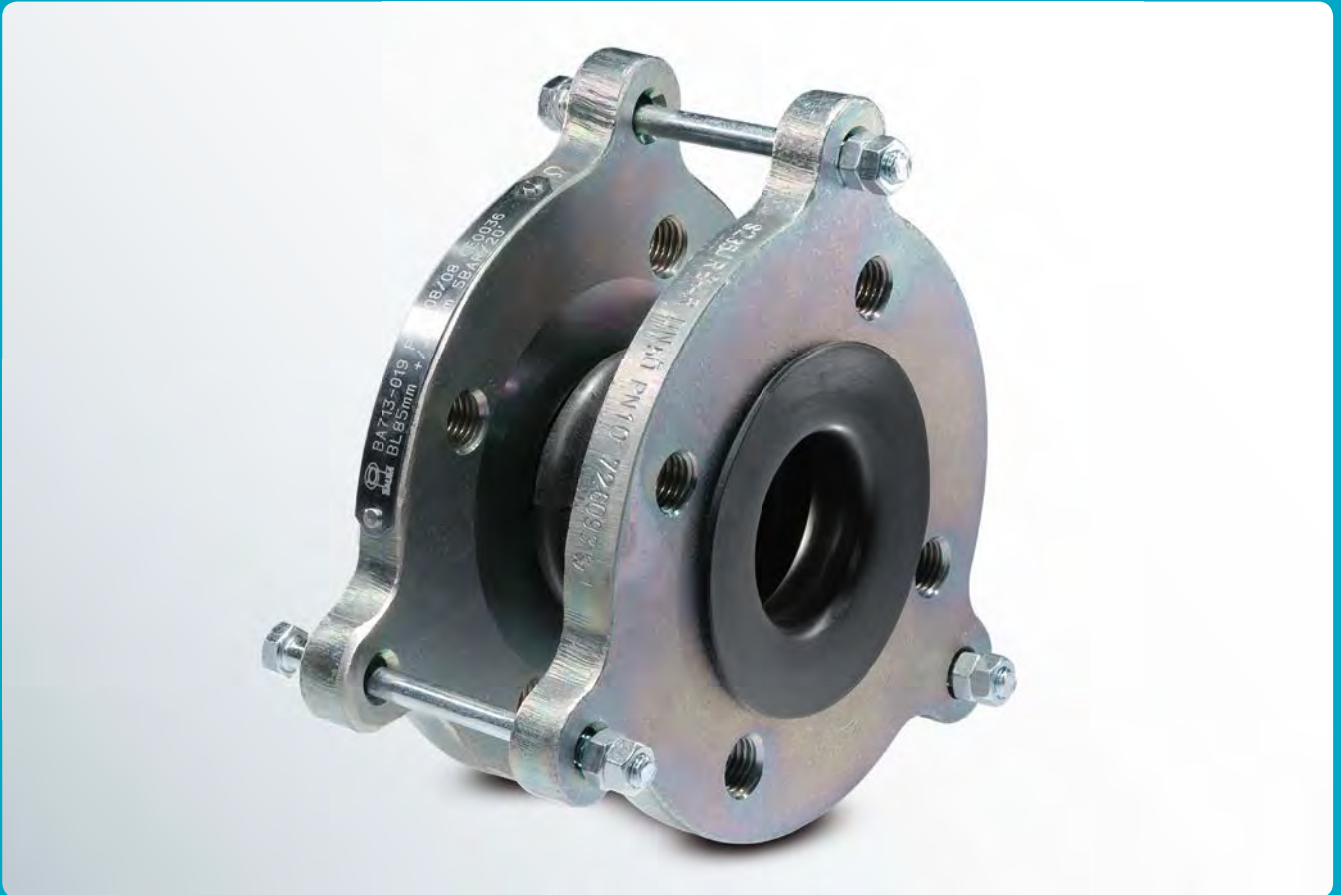

PTFE Expansion Joints, 3 convolutes (Class 150) – BAUM-Flex

Designs:

- up to nominal pipe size DN 100 with two ears
- from nominal pipe size DN 125 with three ears
- up to nominal pipe size DN 65 with threaded holes

- from nominal pipe size DN 80 with through holes

Flange materials:

- carbon steel
- up to nominal pipe size DN 300 chromated
- from DN 350 primed

- stainless steel

Lining material:

- PTFE (virgin or conductive)

Flanges:

- loose-loose

Other pressure ratings:

- on request

Special features:

- tie rod

Optional extras:

- final painting
- limit sleeve
- earthing stud/lug

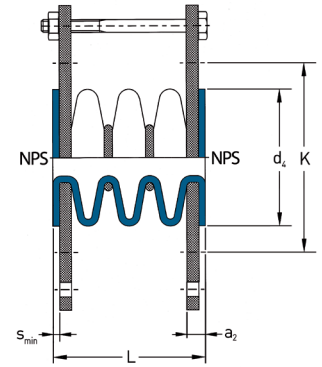

NPS	L	Stroke ±	Lateral offset ±	Angular offset ± max. (°)	d ₄	K	s _{min}	a ₂	No. of bolts x thread (UNC)	Weights (ca. kg/pc.)
>20" on request	(mm)	(mm)	(mm)		(mm)	(mm)	(mm)	(mm)		
½"	70	10	6	6	45	65	3,0	13,0	4 x ½"	1,4
¾"	70	10	6	6	58	75	3,0	13,0	4 x ½"	1,7
1"	70	10	6	6	68	85	3,0	13,0	4 x ½"	1,9
1¼"	75	10	6	6	78	100	3,0	13,0	4 x ½"	2,5
1½"	80	15	6	6	88	110	3,0	13,0	4 x ½"	3,0
2"	85	15	9	8	102	125	4,0	16,0	4 x ⅝"	4,1
2½"	100	20	9	8	122	145	4,0	16,0	4 x ⅝"	5,1
3"	110	20	13	10	138	160	4,0	16,0	4 x ⅝"	6,0
4"	110	25	13	10	158	180	5,0	20,0	8 x ⅝"	7,9
5"	120	25	14	10	188	210	4,5	19,5	8 x ¾"	10,9
6"	130	25	14	8	212	240	5,0	23,0	8 x ¾"	15,6
8"	140	30	14	8	268	295	7,5	27,5	8 x ¾"	27,2
10"	165	30	14	6	320	350	7,5	29,5	12 x ⅞"	34,1
12"	175	30	15	6	370	400	7,5	32,5	12 x ⅞"	57,4
14"	190	30	15	6	430	460	7,5	37,5	12 x 1"	75,2
16"	190	35	15	6	482	515	7,0	37,0	16 x 1"	89,6
20"	190	35	20	5	585	620	7,5	37,5	20 x 1⅛"	103,4

NPS	Overpressure resistance (10 ⁵ Pa) at				Vacuum resistance (10 ⁵ Pa) at		
	23°C	100°C	150°C	200°C	23°C	100°C	150°C
½"	10,0	7,7	6,1	4,9	-1,00	-1,00	-1,00
¾"	10,0	7,7	6,1	4,9	-1,00	-1,00	-1,00
1"	10,0	7,7	6,1	4,9	-1,00	-1,00	-1,00
1¼"	10,0	7,7	6,1	4,9	-1,00	-1,00	-1,00
1½"	10,0	7,7	6,1	4,9	-1,00	-1,00	-1,00
2"	10,0	7,7	6,1	4,9	-1,00	-1,00	-1,00
2½"	10,0	6,5	5,2	4,2	-1,00	-1,00	-1,00
3"	10,0	6,5	5,2	4,2	-1,00	-1,00	-1,00
4"	10,0	6,5	5,2	4,2	-1,00	-1,00	-1,00
5"	8,7	5,1	4,1	3,3	-1,00	-1,00	-1,00
6"	8,7	5,1	4,1	3,3	-1,00	-1,00	-1,00
8"	6,0	3,5	2,8	2,3	-1,00	-1,00	-0,79
10"	6,0	3,5	2,8	2,3	-1,00	-0,85	-0,66
12"	6,0	3,5	2,8	2,3	-0,83	-0,70	-0,53

Different nominal pipe sizes and total lengths on request.

L = Total length

d₄ = Raised face diameter

K = Bolt circle diameter

s_{min} = Minimum liner thickness

a₂ = Minimum length with loose flange and s_{min}

Technical data valid for the pressure rating Class 150. a₂ depends on construction type and lining thickness.

The overpressure resistance is only valid at neutral position of the PTFE Expansion Joint with limit bolts in place. The types of travel stroke, lateral offset and angular offset are maximum allowable movements in only one direction. For superpositioned movement the single types of travel need to be limited. The figures stated are average and apply to room temperature.

PTFE Expansion Joints, 4 convolutes (Class 150)

Our PTFE Expansion Joints are highly flexible and provide compensation of vibrations and heat-induced expansion in your production line. The possible absorption of movement is increased by a higher number of convolutes.

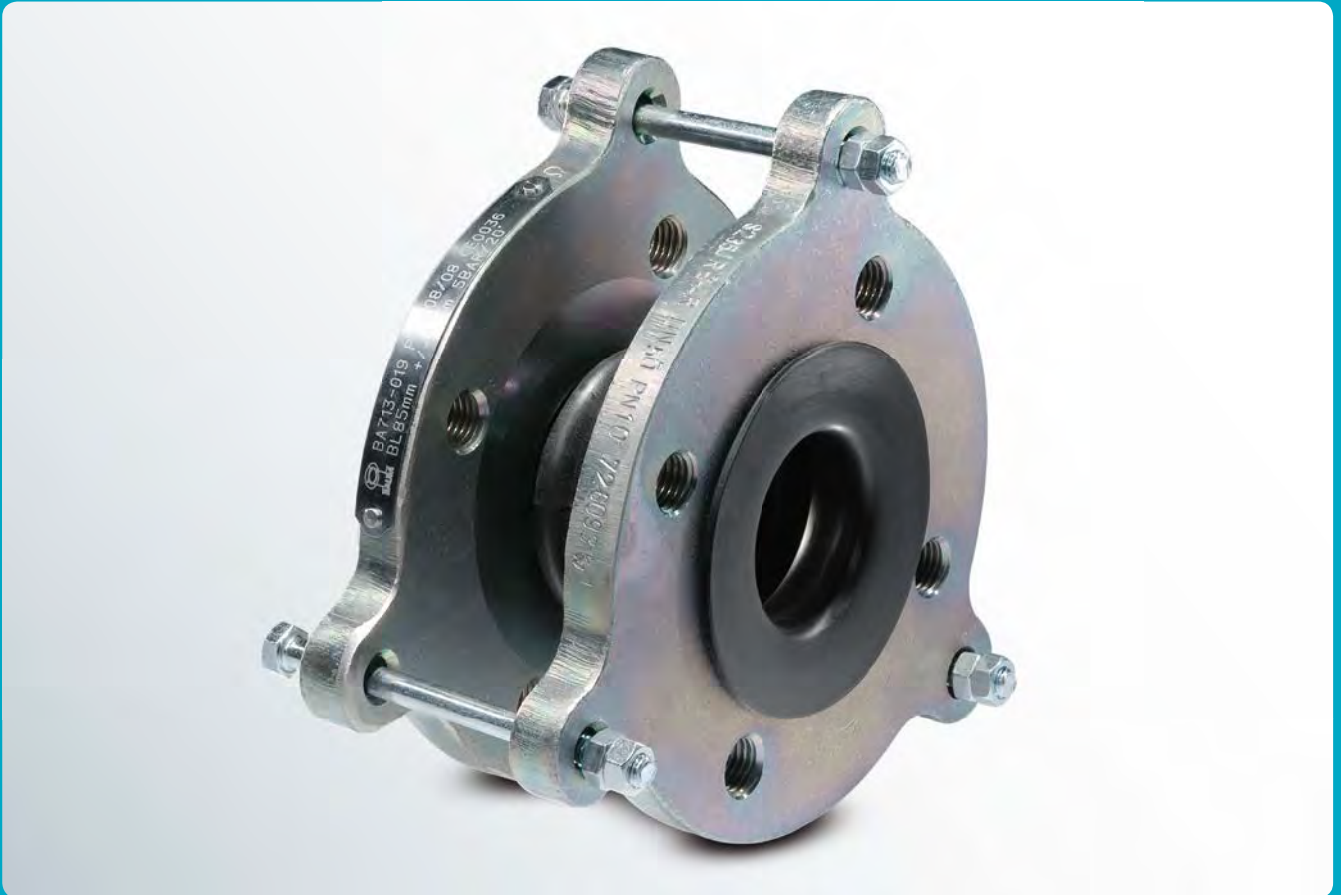

PTFE Expansion Joints, 4 convolutes (Class 150) – BAUM-Flex

Designs:

- up to nominal pipe size DN 100 with two ears
- from nominal pipe size DN 125 with three ears
- up to nominal pipe size DN 65 with threaded holes
- from nominal pipe size DN 80 with through holes

Flange materials:

- carbon steel
- up to nominal pipe size DN 300 chromated
- from DN 350 primed
- stainless steel

Lining material:

- PTFE (virgin or conductive)

Flanges:

- loose-loose

Other pressure ratings:

- on request

Special features:

- tie rod

Optional extras:

- final painting
- limit sleeve
- earthing stud/lug

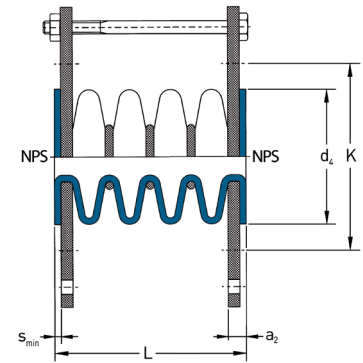

NPS	L	Stroke ±	Lateral offset ±	Angular offset ± max. (°)	d ₄	K	s _{min}	a ₂	No. of bolts x thread (UNC)	Weights (ca. kg/pc.)
>20" on request	(mm)	(mm)	(mm)		(mm)	(mm)	(mm)	(mm)		
½"	85	13	6	8	45	65 [±]	3,0	13,0	4 x ½"	1,4
¾"	85	13	6	8	58	75	3,0	13,0	4 x ½"	1,7
1"	85	13	6	8	68	85	3,0	13,0	4 x ½"	1,9
1¼"	90	13	6	8	78	100	3,0	13,0	4 x ½"	2,6
1½"	98	18	6	8	88	110	3,0	13,0	4 x ½"	3,0
2"	105	20	10	9	102	125	4,0	16,0	4 x ⅝"	4,2
2½"	122	25	10	10	122	145	4,0	16,0	4 x ⅝"	5,2
3"	135	26	12	11	138	160	4,0	16,0	4 x ⅝"	6,0
4"	137	33	15	13	158	180	5,0	20,0	8 x ⅝"	8,2
5"	145	33	15	13	188	210	4,5	19,5	8 x ¾"	11,3
6"	155	33	15	12	212	240	5,0	23,0	8 x ¾"	16,1
8"	175	40	18	10	268	295	7,5	27,5	8 x ¾"	27,9
10"	195	40	18	10	320	350	7,5	29,5	12 x ⅞"	33,4
12"	215	45	18	9	370	400	7,5	32,5	12 x ⅞"	58,7
14"	235	50	22	8	430	460	7,5	37,5	12 x 1"	77,0
16"	235	50	22	8	482	515	7,0	37,0	16 x 1"	91,7
20"	235	50	22	6	585	620	7,5	37,5	20 x 1½"	106,0

NPS	Overpressure resistance (10 ⁵ Pa) at				Vacuum resistance (10 ⁵ Pa) at		
	23°C	100°C	150°C	200°C	23°C	100°C	150°C
½"	10,0	6,5	5,2	4,2	-1,00	-1,00	-1,00
¾"	10,0	6,5	5,2	4,2	-1,00	-1,00	-1,00
1"	10,0	6,5	5,2	4,2	-1,00	-1,00	-1,00
1¼"	10,0	6,5	5,2	4,2	-1,00	-1,00	-1,00
1½"	10,0	6,5	5,2	4,2	-1,00	-1,00	-1,00
2"	10,0	6,5	5,2	4,2	-1,00	-1,00	-1,00
2½"	9,4	5,5	4,4	3,6	-1,00	-1,00	-1,00
3"	9,4	5,5	4,4	3,6	-1,00	-1,00	-1,00
4"	9,4	5,5	4,4	3,6	-1,00	-1,00	-1,00
5"	7,4	4,4	3,5	2,8	-1,00	-1,00	-1,00
6"	7,4	4,4	3,5	2,8	-1,00	-1,00	-0,91
8"	5,1	3,0	2,4	1,9	-1,00	-0,90	-0,69
10"	5,1	3,0	2,4	1,9	-0,92	-0,77	-0,59
12"	5,1	3,0	2,4	1,9	-0,77	-0,64	-0,51

Different nominal pipe sizes and total lengths on request.

L = Total length

d₄ = Raised face diameter

K = Bolt circle diameter

s_{min} = Minimum liner thickness

a₂ = Minimum length with loose flange and s_{min}

Technical data valid for the pressure rating Class 150. a₂ depends on construction type and lining thickness.

The overpressure resistance is only valid at neutral position of the PTFE Expansion Joint with limit bolts in place. The types of travel stroke, lateral offset and angular offset are maximum allowable movements in only one direction. For superpositioned movement the single types of travel need to be limited. The figures stated are average and apply to room temperature.

PTFE Expansion Joints, 5 convolutes (Class 150)

Our PTFE Expansion Joints are highly flexible and provide compensation of vibrations and heat-induced expansion in your production line. PTFE Expansion Joints with 5 convolutes allow the maximum absorption of movement.



PTFE Expansion Joints, 5 convolutes (Class 150) – BAUM-Flex

Designs:

- up to nominal pipe size DN 100 with two ears
- from nominal pipe size DN 125 with three ears
- up to nominal pipe size DN 65 with threaded holes
- from nominal pipe size DN 80 with through holes

Flange materials:

- carbon steel
- up to nominal pipe size DN 300 chromated
- from DN 350 primed
- stainless steel

Lining material:

- PTFE (virgin or conductive)

Flanges:

- loose-loose

Other pressure ratings:

- on request

Special features:

- tie rod

Optional extras:

- final painting
- limit sleeve
- earthing stud/lug

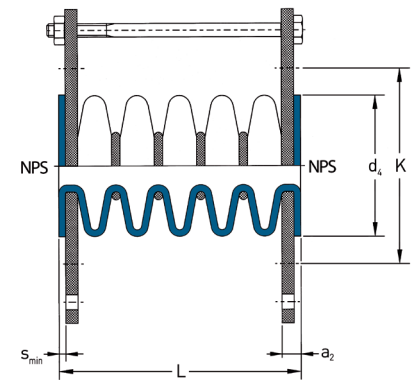

NPS >20" on request	L (mm)	Stroke ± (mm)	Lateral offset ± (mm)	Angular offset ± max. (°)	d ₄ (mm)	K (mm)	s _{min} (mm)	a ₂ (mm)	No. of bolts x thread (UNC)	Weights (ca. kg/pc.)
1/2"	100	15	8	10	45	65	3,0	13,0	4 x 1/2"	1,4
3/4"	100	15	8	10	58	75	3,0	13,0	4 x 1/2"	1,8
1"	100	15	8	10	68	85	3,0	13,0	4 x 1/2"	1,9
1 1/4"	105	15	8	10	78	100	3,0	13,0	4 x 1/2"	2,6
1 1/2"	115	20	8	12	88	110	3,0	13,0	4 x 1/2"	3,1
2"	125	25	12	12	102	125	4,0	16,0	4 x 5/8"	4,3
2 1/2"	145	30	15	14	122	145	4,0	16,0	4 x 5/8"	5,3
3"	160	35	18	16	138	160	4,0	16,0	4 x 5/8"	6,2
4"	165	40	18	16	158	180	5,0	20,0	8 x 5/8"	8,5
5"	170	40	18	14	188	210	4,5	19,5	8 x 3/4"	11,7
6"	180	40	22	13	212	240	5,0	23,0	8 x 3/4"	16,5
8"	210	50	22	13	268	295	7,5	27,5	8 x 3/4"	29,0
10"	240	50	22	12	320	350	7,5	29,5	12 x 7/8"	36,9
12"	250	50	22	10	370	400	7,5	32,5	12 x 7/8"	61,1
14"	265	50	25	8	430	460	7,5	37,5	12 x 1"	79,7
16"	265	50	25	7	482	515	7,0	37,0	16 x 1"	94,2
20"	280	50	25	6	585	620	7,5	37,5	20 x 1 1/8"	109,7

NPS	Overpressure resistance (10 ⁵ Pa) at				Vacuum resistance (10 ⁵ Pa) at		
	23° C	100° C	150° C	200° C	23° C	100° C	150° C
1/2"	9,7	5,7	4,6	3,7	-1,00	-1,00	-1,00
3/4"	9,7	5,7	4,6	3,7	-1,00	-1,00	-1,00
1"	9,7	5,7	4,6	3,7	-1,00	-1,00	-1,00
1 1/4"	9,7	5,7	4,6	3,7	-1,00	-1,00	-1,00
1 1/2"	9,7	5,7	4,6	3,7	-1,00	-1,00	-1,00
2"	9,7	5,7	4,6	3,7	-1,00	-1,00	-1,00
2 1/2"	8,3	4,9	3,9	3,2	-1,00	-1,00	-1,00
3"	8,3	4,9	3,9	3,2	-1,00	-1,00	-1,00
4"	8,3	4,9	3,9	3,2	-1,00	-1,00	-0,89
5"	6,5	3,8	3,1	2,5	-1,00	-0,88	-0,81
6"	6,5	3,8	3,1	2,5	-0,92	-0,79	-0,71
8"	4,5	2,7	2,1	1,7	-0,81	-0,70	-0,61
10"	4,5	2,7	2,1	1,7	-0,69	-0,67	-0,52
12"	4,5	2,7	2,1	1,7	-0,68	-0,57	-0,43

Different nominal pipe sizes and total lengths on request.

L = Total length

d₄ = Raised face diameter

K = Bolt circle diameter

s_{min} = Minimum liner thickness

a₂ = Minimum length with loose flange and s_{min}

Technical data valid for the pressure rating Class 150. a₂ depends on construction type and lining thickness.

The overpressure resistance is only valid at neutral position of the PTFE Expansion Joint with limit bolts in place. The types of travel stroke, lateral offset and angular offset are maximum allowable movements in only one direction. For superpositioned movement the single types of travel need to be limited. The figures stated are average and apply to room temperature.

PTFE Lined Stainless Steel Expansion Joints (Class 150)

In case of high pressures and high temperatures, our PTFE Lined Stainless Steel Expansion Joints are the right choice for your pipes.

Stainless Steel Expansion Joints are the most stable expansion joints.

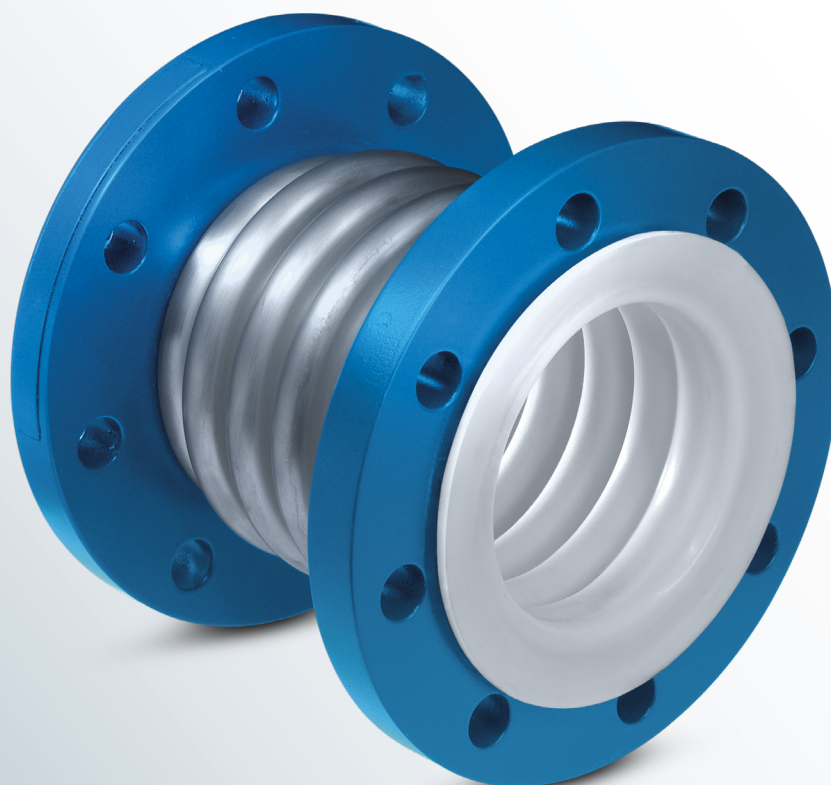

PTFE Lined Stainless Steel Expansion Joints (Class 150)

BAUM-SteelFlex

Flange materials:

- carbon steel
- stainless steel

Lining material:

- PTFE (virgin or conductive)

Bellow material:

- stainless steel

Flanges:

- loose-loose

Other pressure rating:

- Class 300

Special features:

- earthing stud/lug

Optional extras:

- final painting (flanges)

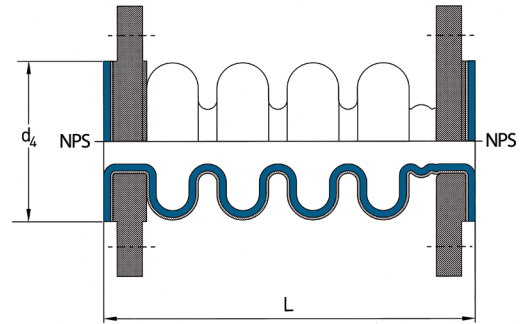

NPS	L (mm)	Stroke ± (mm)	Axial spring rate (N/mm)	Nominal movement absorption apply to 1.000 load changes ±		Vacuum resistance (10 ⁵ Pa) at		d ₄ (mm)	No. of bolts x thread (UNC)	Weights (ca. kg/pc.)
				angular degree	lateral mm	23° C	160° C			
1½"	145	4.5	260	10,0	4,45	0.15	0.30	63.5	4 x ½"	4.0
1½"	220	9.0	130	15,5	14,0	0.15	0.30	63.5	4 x ½"	4.0
1½"	155	5.5	272	10,0	4,55	0.15	0.30	73.0	4 x ½"	5.0
1½"	240	11.0	136	15,0	11,5	0.15	0.30	73.0	4 x ½"	5.0
2"	177	6.5	276	9,5	2,95	0.15	0.30	92.1	4 x ⅝"	6.0
2"	292	13.5	195	16,0	11,5	0.15	0.30	92.1	4 x ⅝"	6.0
2½"	179	8.5	234	10,0	4,5	0.15	0.30	104.8	4 x ⅝"	7.0
2½"	285	16.0	173	15,0	17,5	0.15	0.30	104.8	4 x ⅝"	7.5
3"	183	10.0	220	20,0	2,8	0.15	0.30	127.0	4 x ⅝"	7.5
3"	273	17.5	178	14,5	14,5	0.15	0.30	127.0	4 x ⅝"	8.5
4"	178	10.0	365	8,5	3,4	0.15	0.30	157.2	8 x ⅝"	10.0
4"	266	20.0	183	14,0	11,0	0.15	0.30	157.2	8 x ⅝"	11.5
5"	221	14.5	290	10,0	10,0	0.25	0.40	185.7	8 x ¾"	13.0
5"	363	25.0	290	15,0	15,5	0.25	0.40	185.7	8 x ¾"	15.0
6"	248	15.0	560	9,0	10,0	0.25	0.40	215.9	8 x ¾"	17.0
6"	388	30.0	280	14,5	15,0	0.25	0.40	215.9	8 x ¾"	20.0
8"	246	21.0	412	9,5	9,5	0.35	0.50	269.9	8 x ¾"	24.0
8"	418	39.0	335	15,0	16,0	0.35	0.50	269.9	8 x ¾"	30.0
10"	243	22.0	525	8,5	10,0	0.40	0.60	323.8	12 x ⅞"	32.0
10"	392	40.5	269	12,0	15,0	0.40	0.60	323.8	12 x ⅞"	35.0
12"	287	27.5	480	8,5	10,0	0.50	0.75	381.0	12 x ⅞"	37.0
12"	429	47.5	352	12,5	14,5	0.50	0.75	381.0	12 x ⅞"	43.0
14"	296	30.0	460	8,5	8,5	0.50	0.75	412.8	12 x 1"	51.0
14"	407	46.0	378	11,5	14,0	0.50	0.75	412.8	12 x 1"	57.0
16"	290	26.0	713	6,5	10,0	0.70	0.90	469.9	16 x 1"	68.0
16"	434	52.0	357	11,0	15,0	0.70	0.90	469.9	16 x 1"	75.0
18"	328	35.0	548	7,5	14,0	0.70	0.90	533.4	16 x 1⅛"	76.0
18"	535	65.0	430	12,0	14,5	0.70	0.90	533.4	16 x 1⅛"	97.0
20"	309	28.0	955	6,0	9,5	-	-	584.2	20 x 1⅛"	97.0
20"	509	63.0	425	11,0	15,0	-	-	584.2	20 x 1⅛"	113.0
24"	336	35.0	548	6,0	8,5	-	-	692.2	20 x 1¼"	118.0

Different nominal pipe sizes and total lengths on request.

L = Total length

d₄ = Raised face diameter

Technical data valid for the pressure rating Class 150.

PTFE Vacuum Expansion Joints (Class 150)

PTFE Vacuum Expansion Joints allow full vacuum, also in case of large nominal widths and high temperatures.



PTFE Vacuum Expansion Joints (Class 150) – BAUM-Vac

Designs:

- up to nominal pipe size NPS 4" with two ears
- from nominal pipe size NPS 5" with three ears
- up to nominal pipe size NPS 2 1/2" with threaded holes
- from nominal pipe size NPS 3" with through holes

Flange materials:

- carbon steel
- stainless steel

Lining material:

- PTFE (virgin or conductive)

Flanges:

- loose-loose

Other pressure ratings:

- on request

Special features:

- limit bolts/hole extensions
- earthing stud/lug

Optional extras:

- final painting

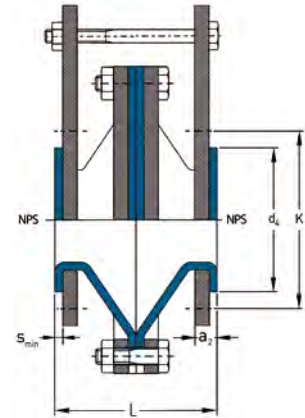

NPS	L (mm)	Stroke ± (mm)	Lateral offset (mm)	Angular offset (mm)	d ₄ (mm)	K (mm)	s _{min} (mm)	a ₂ (mm)	No. of bolts x thread (UNC)	Weights (ca. kg/pc.)
4"	150	12	3	4	157.2	190.5	7.5	22.5	8 x 5/8"	19.9
5"	150	12	4	4	185.7	215.9	7.5	22.5	8 x 3/4"	24.9
6"	150	12	4	4	215.9	241.3	7.5	25.5	8 x 3/4"	28.8
8"	150	15	5	4	269.9	298.5	7.5	27.5	8 x 3/4"	44.7
10"	150	15	6	4	323.8	362.0	7.5	29.5	12 x 7/8"	56.6
12"	150	20	7	4	381.0	431.8	7.5	32.5	12 x 7/8"	91.4
14"	160	20	7	4	412.8	476.3	7.5	37.5	12 x 1"	117.2
16"	160	20	8	3	469.9	539.8	7.5	37.5	16 x 1"	126.7
20"	160	20	9	3	584.2	635.0	8.0	38.0	20 x 1 1/8"	130.1
24"	170	Please determine the desired standard - ASME B 16.47 Series A/B or British Standard 3293 - when contacting our sales department.								
28"	170									
32"	170									
36"	170									
40"	170									

NPS	Overpressure resistance (10 ⁵ Pa) at		Vacuum resistance (10 ⁵ Pa) at
	23° C	200° C	200° C
4"	3.0	3.0	-1.0
5"	3.0	3.0	-1.0
6"	3.0	3.0	-1.0
8"	3.0	3.0	-1.0
10"	3.0	3.0	-1.0
12"	3.0	3.0	-1.0
14"	3.0	3.0	-1.0
16"	3.0	1.0	-1.0
18"	3.0	1.0	-1.0
20"	3.0	1.0	-1.0
24"	3.0	1.0	-1.0
28"	1.0	0.5	-1.0
32"	0.5	0.3	-1.0
36"	0.1	0.1	-1.0
40"	0.0	0.0	-1.0

Different nominal pipe sizes and total lengths on request.

- L = Total length
- d₄ = Raised face diameter
- K = Bolt circle diameter
- s_{min} = Minimum flare thickness

Technical data valid for the pressure rating Class 150. a₂ depends on construction type and lining thickness.

The overpressure resistance is only valid at neutral position of the PTFE Vacuum Expansion Joint with limit bolts in place. The types of travel stroke, lateral offset and angular offset are maximum allowable movements in only one direction. For superpositioned movement the single types of travel need to be limited. The figures stated are average and apply to room temperature.

Spectacle Blinds



Spectacle Blinds (Class 150)

With Spectacle Blinds it is possible to separate pipe sections.



Spectacle Blinds (Class 150)

Materials:

- carbon steel
- stainless steel

Lining material:

- PFA (virgin or conductive)

Other pressure rating:

- Class 300

Special features:

- earthing stud/lug

Optional extras:

- final painting

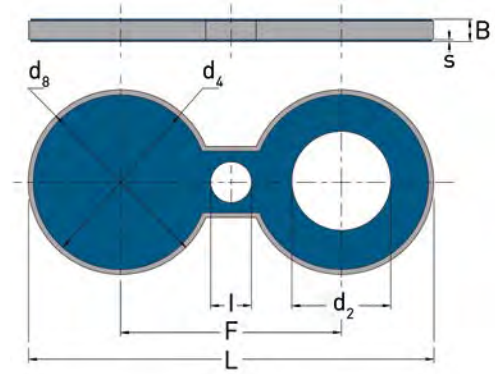

NPS	L (mm)	B _{min} (mm)	d ₂ (mm)	d ₄ (mm)	d ₈ (mm)	s (mm)	F (mm)	l (mm)	Weights (ca. kg/pc.)
½"	100.5	17.2	14.9	34.9	40	4.0	60.5	15.7	0.3
¾"	117.9	18.7	14.9	42.9	48	4.0	69.9	15.7	0.4
1"	134.2	20.2	20.6	50.8	55	4.0	79.2	15.7	0.6
1¼"	156.9	21.7	29.0	63.5	68	4.0	88.9	15.7	0.9
1½"	173.6	23.7	34.9	73.0	75	4.0	98.6	15.7	1.3
2"	215.7	25.1	46.5	92.1	95	4.0	120.7	19.1	2.2
2½"	247.7	28.4	56.6	104.8	108	4.0	139.7	19.1	3.2
3"	282.3	29.9	71.9	127.0	130	4.0	152.3	19.1	4.6
4"	350.5	29.9	96.3	157.2	160	4.0	190.5	19.1	6.8
5"	405.9	29.9	122.1	185.7	190	4.0	215.9	22.4	9.2
6"	459.3	31.4	148.1	215.9	218	4.0	241.3	22.4	12.4
8"	572.5	34.4	196.7	269.9	274	4.0	298.5	22.4	21.0
10"	690.0	36.2	248.4	323.8	328	4.0	362.0	25.4	30.6
12"	816.8	37.8	298.8	381.0	385	4.0	431.8	25.4	43.5

Different nominal pipe sizes and total lengths on request.

L = Total length
 B_{min} = Minimum thickness
 d₂ = Inner diameter
 d₄ = Raised face diameter
 d₈ = Outer diameter
 s = Lining thickness
 F = Distance of the circle centers
 l = Quick-release axle diameter
 Technical data valid for the pressure rating Class 150.
 B depend on construction type and lining thickness.

NPS	Lining thickness		Possible vacuum		
	standard	thick-walled	23° C	150° C	200° C
1"	●	●	▬	▬	▬
1½"	●	●	▬	▬	▬
2"	●	●	▬	▬	▬
3"	●	●	▬	▬	▬
4"	●	●	▬	▬	▬
6"	●	●	▬	▬	▬
8"	●	●	▬	▬	▬
10"	●	●	▬	▬	▬
12"	●	●	▬	▬	▬

Vacuum resistance:

- ▬ = full vacuum
- ▬ = limited vacuum
- = no vacuum

Please refer to the next higher nominal pipe size if your nominal pipe size is not listed.

Nozzle Liners / Dip Pipes



PTFE Nozzle Liners (Class 150)

PTFE Nozzle Liners protect tank walls during the filling with corrosive media.



PTFE Nozzle Liners (Class 150)

Material:

- PTFE (virgin or conductive)

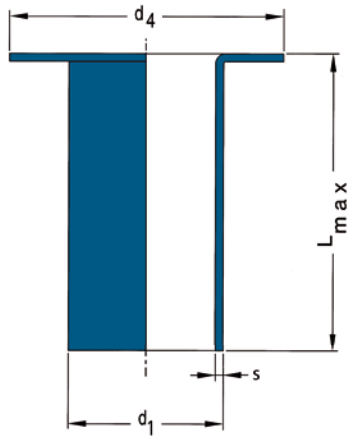

NPS	L_{max} (mm)	d_1 (mm)	d_4 (mm)	s (mm)	Tolerance for d_1 \pm (mm)	Weights (ca. kg/m)
1"	6000	19	50.8	3.0	2	0.3
1¼"	6000	27	63.5	3.0	2	0.5
1½"	6000	32	73.0	4.0	2	0.8
2"	6000	43	92.1	4.0	3	1.1
2½"	6000	51	104.8	4.0	4	1.3
3"	6000	66	127.0	4.0	4	1.7
4"	6000	89	157.2	4.0	5	2.3
5"	6000	114	185.7	4.5	5	3.3
6"	6000	139	215.9	4.5	5	4.1
8"	6000	182	269.9	5.0	6	6.0
10"	4000	225	323.8	5.0	10	7.4
12"	4000	283	381.0	5.0	10	9.4
14"	4000	316	412.8	5.0	10	10.5
16"	4000	363	469.9	7.5	10	18.0
20"	2000	468	584.2	8.0	10	24.9

Different outer diameters of the pipe and raised face diameters on request.

L_{max} = Maximum total length

d_1 = Outer diameter of the pipe

d_4 = Raised face diameter

s = Lining thickness

Technical data valid for the pressure rating Class 150.

PTFE-lined Dip Pipes (Class 150)

PTFE-lined Dip Pipes allow the precise feeding of corrosive media into tanks. Nozzle heads additionally offer the possibility of a directed dispersion of operating media.



PTFE-lined Dip Pipes (Class 150) for calm vessels (standard type)

Designs:

- welded
- seamless

Materials:

- carbon steel
- stainless steel

Lining material:

- PTFE (virgin or conductive)

Other pressure rating:

- Class 300

Special features:

- earthing stud/lug
- vent hole extensions
- nozzle head

Optional extras:

- final painting
- bended design

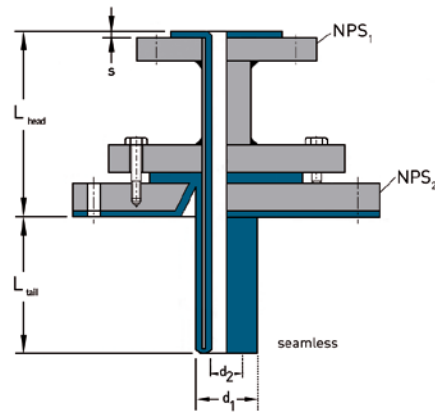
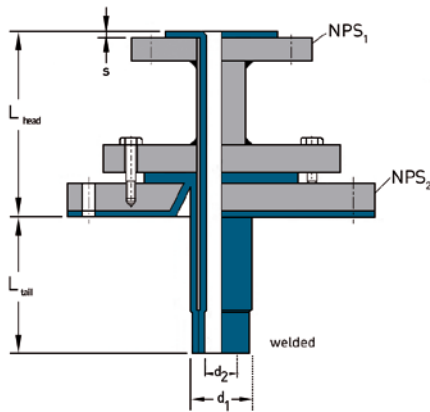

NPS ₁	NPS ₂	Steel pipe outer diam. x wall (mm x mm)	L _{Head} (mm)	L _{tail, max} (mm)		d ₁ (mm)	d ₂ (mm)	s (mm)
				welded	seamless			
1"	Please indicate with your order.	33.7 x 2.6	150	4000	2800	21.5	40.7	3.5
1¼"		42.4 x 2.6	150	4000	2800	29.2	50.4	4.0
1½"		48.3 x 2.6	150	4000	2800	35.1	56.3	4.0
2"		60.3 x 2.9	150	4000	2800	46.5	68.3	4.0
2½"		76.1 x 2.9	150	4000	2800	62.3	84.1	4.0
3"		88.9 x 3.2	150	4000	2800	74.5	96.9	4.0
4"		114.3 x 3.6	150	4000	2500	97.1	124.3	5.0
5"		139.7 x 4.0	150	4000	2500	122.7	148.7	4.5
6"		168.3 x 4.5	150	4000	2500	149.3	178.3	5.0
8"		219.1 x 6.3	150	4000	2000	196.5	229.1	5.0
10"		273.0 x 6.3	150	3000	1500	248.4	285.0	6.0
12"		323.9 x 7.1	150	3000	1500	297.7	335.9	6.0
14"		355.6 x 8.0	150	2000	-	327.6	367.6	6.0
16"		406.4 x 8.8	150	2000	-	378.8	416.4	5.0

Different nominal pipe sizes and wall thicknesses on request.

- L_{head} = Total length head
- L_{tail, max} = Maximum total length tail
- d₁ = Outer diameter of the pipe
- d₂ = Inner diameter of the pipe
- s = Lining thickness

Technical data valid for the pressure rating Class 150.

PTFE-lined Dip Pipes (Class 150) for agitated vessels (reinforced type)

Designs:

- welded
- seamless

Materials:

- carbon steel
- stainless steel

Lining material:

- PTFE (virgin or conductive)

Other pressure rating:

- Class 300

Special features:

- earthing stud/lug
- vent hole extensions
- nozzle head

Optional extras:

- final painting
- **bended design**

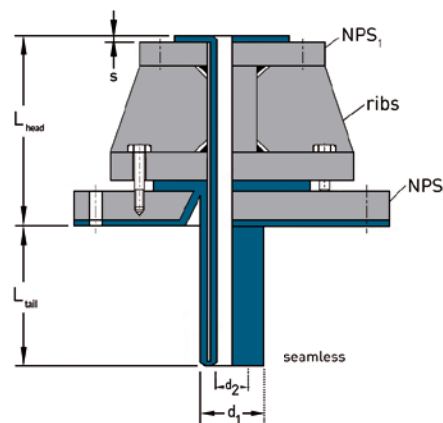
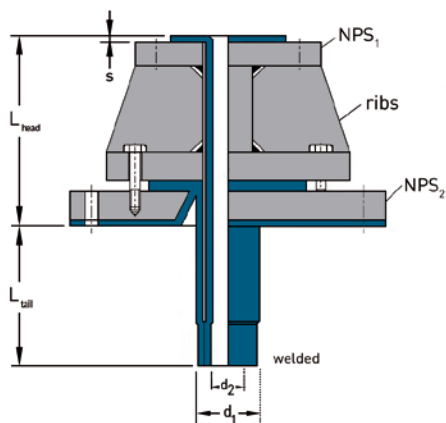

NPS ₁	NPS ₂	Steel pipe outer diam. x wall (mm x mm)	L _{Head} (mm)	L _{tail, max} (mm)		d ₁ (mm)	d ₂ (mm)	s (mm)
				welded	seamless			
1"	Please indicate with your order.	33.7 x 4.0	150	4000	2000	18.7	40.7	3.5
1¼"		42.4 x 6.3	150	4000	2000	21.8	50.4	4.0
1½"		48.3 x 6.3	150	4000	2000	27.7	56.3	4.0
2"		60.3 x 8.0	150	4000	-	36.3	68.3	4.0
2½"		76.1 x 10.0	150	4000	-	48.1	84.1	4.0
3"		88.9 x 10.0	150	4000	-	60.9	96.9	4.0
4"		114.3 x 10.0	150	4000	-	84.3	124.3	5.0
5"		139.7 x 10.0	150	4000	-	110.7	148.7	4.5
6"		168.3 x 16.0	150	4000	-	126.3	178.3	5.0
8"		219.1 x 16.0	150	4000	-	177.1	229.1	5.0
10"		273.0 x 16.0	150	3000	-	229.0	285.0	6.0
12"		323.9 x 16.0	150	3000	-	279.9	335.9	6.0

Different nominal pipe sizes and wall thicknesses on request.

- L_{head} = Total length head
- L_{tail, max} = Maximum total length tail
- d₁ = Outer diameter of the pipe
- d₂ = Inner diameter of the pipe
- s = Lining thickness

Technical data valid for the pressure rating Class 150.

Hoses



PTFE Chemical Transfer Hoses (Class 150) – smooth bore with stripwound house

The stripwound hose is a metal protection hose with a high mechanical strength, for higher pressures; the hose is torsion-proofed, high tensile and it has a straight PTFE liner.



PTFE Chemical Transfer Hoses (Class 150) – smooth bore with stripwound hose

Materials Flanges:

- carbon steel
- stainless steel

Material Hoses:

- stainless steel

Lining material:

- PTFE (virgin or conductive)

Flanges:

- fix-fix
- fix-loose
- loose-loose

Other pressure rating:

- Class 300

Special features:

- earthing stud/lug
- flange stopper

Optional extras:

- final painting (flanges)

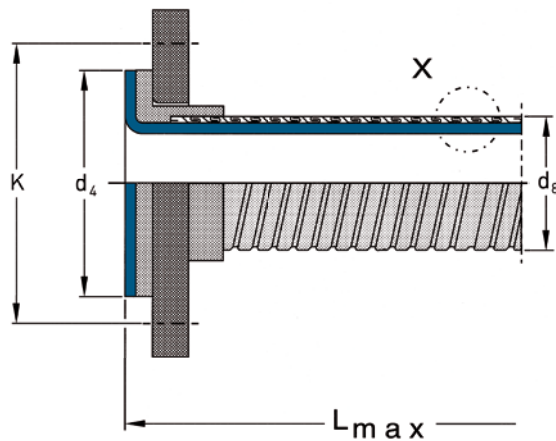

Detail X



NPS	L _{max} (mm)	Min. bend radius (mm)	Max. working pressure (10 ⁵ Pa)	d ₄ (mm)	d ₆ (mm)	K (mm)	No. of bolts x thread (UNC)	Weights	
								Hose (ca. kg/m)	Flange (ca. kg/side)
1/2"	5000	325	10.0	34.9	19	60.3	4 x 1/2"	0.5	0.4
3/4"	5000	350	10.0	42.9	23	69.9	4 x 1/2"	0.6	0.6
1"	5000	350	10.0	50.8	28	79.4	4 x 1/2"	0.9	0.8
1 1/4"	5000	400	10.0	63.5	35	88.9	4 x 1/2"	1.1	1.0
1 1/2"	5000	550	10.0	73.0	45	98.4	4 x 1/2"	1.6	1.3
2"	5000	750	10.0	92.1	55	120.7	4 x 5/8"	2.0	2.0
3"	5000	1300	10.0	127.0	87	152.4	4 x 5/8"	5.0	3.8
4"	5000	1500	7.5	157.2	100	190.5	8 x 5/8"	6.8	5.3

Different nominal pipe sizes on request.

L_{max} = Maximum length
d₄ = Raised face diameter
d₆ = Outer diameter
K = Bolt circle diameter
Technical data valid for the pressure rating Class 150.

PTFE Chemical Transfer Hoses (Class 150) – smooth bore/annularly corrugating/wire braid

The annularly corrugated hose shows a multitude of self-contained and parallel metal convolutes in equal distance. The annularly corrugated hose has a braiding

to increase the pressure resistance. It has a straight PTFE lining.



PTFE Chemical Transfer Hoses (Class 150) – smooth bore with annularly corrugating and wire braid

Materials Flanges:

- carbon steel
- stainless steel

Material Hoses:

- stainless steel

Lining material:

- PTFE (virgin or conductive)

Flanges:

- fix-fix
- fix-loose
- loose-loose

Other pressure rating:

- Class 300

Special features:

- earthing stud/luge
- flange stopper

Optional extras:

- final painting (flanges)

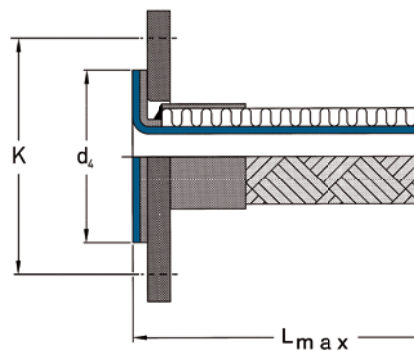

NPS	L _{max} (mm)	Min. bend radius (mm)	Max. working pressure (10 ⁵ Pa)	d _k (mm)	K (mm)	No. of bolts x thread (UNC)	Weights	
							Hose (ca. kg/m)	Flange (ca. kg/side)
1"	5000	350	25	50.8	79.4	4 x 1/2"	0.8	0.8
1 1/4"	5000	400	20	63.5	88.9	4 x 1/2"	1.0	1.0
1 1/2"	5000	550	16	73.0	98.4	4 x 1/2"	1.6	1.3
2"	5000	750	16	92.1	120.7	4 x 5/8"	1.6	2.0
2 1/2"	5000	1000	14	104.8	139.7	4 x 5/8"	1.8	3.3
3"	5000	1300	12	127.0	152.4	4 x 5/8"	2.6	3.8
4"	5000	1500	10	157.2	190.5	8 x 5/8"	3.5	5.3
5"	5000	1800	10	185.7	215.9	8 x 3/4"	5.8	6.0
6"	5000	2000	10	215.9	241.3	8 x 3/4"	8.2	7.4
8"	5000	2500	10	269.9	298.5	8 x 3/4"	11.0	12.0

Different nominal
pipe sizes on request.

L_{max} = Maximum length
d_k = Raised face diameter
K = Bolt circle diameter
Technical data valid for the
pressure rating Class 150.

PTFE Spiral Hoses (Class 150)

The spiral-convoluted PTFE hose offers a high flexibility, but shows a low pressure resistance.



PTFE Spiral Hoses (Class 150)

Lining material:

- PTFE (virgin or conductive)

Other pressure rating:

- Class 300

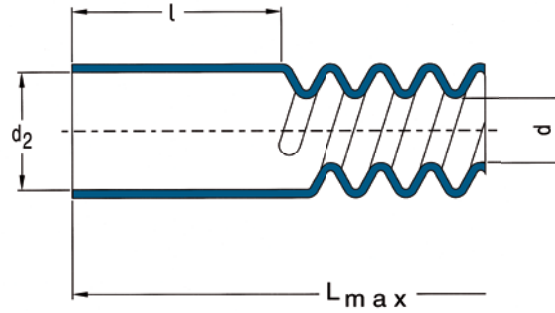

NPS	L_{max} (mm)	l (mm)	Min. bend radius (mm)	Max. working pressure (10^5 Pa)	d (mm)	d_2 (mm)	Weights (ca. kg/m)
1/2"	5000	50	60	1.50	15	23	0.4
3/4"	5000	50	60	1.50	19	30	0.5
1"	5000	50	80	1.50	25	35	0.5
1 1/2"	5000	75	110	1.25	38	48	0.6
2"	5000	75	210	1.25	45	58	0.9
3"	5000	100	400	1.25	70	90	1.8
4"	5000	100	550	1.00	95	115	2.8

Different nominal pipe sizes on request.

L_{max} = Maximum length

l = Cylindrical ending

d = Inner diameter of the spiral tube

d_2 = Inner diameter cylindrical

Technical data valid for the pressure rating Class 150.

PTFE Spiral Hoses (Class 150) with flanges

The spiral-convoluted PTFE hose offers a high flexibility, but shows a low pressure resistance. For connection with PTFE flared flanges.



PTFE Spiral Hoses (Class 150) with flanges

Materials:

- carbon steel
- stainless steel

Lining material:

- PTFE (virgin or conductive)

Flanges:

- fix-fix
- fix-loose
- loose-loose

Other pressure rating:

- Class 300

Special features:

- earthing stud/lug

Optional extras:

- final painting

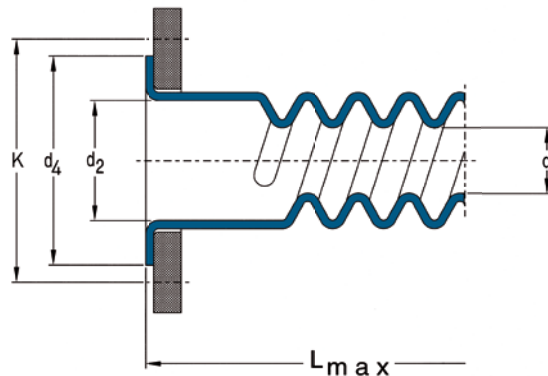

NPS	L _{max} [mm]	Min. bend radius [mm]	Max. working pressure [10 ⁵ Pa]	d [mm]	d ₂ [mm]	d ₄ [mm]	K [mm]	No. of bolts x thread (UNC)	Weights	
									Hose (ca. kg/m)	Flange (ca. kg/side)
1/2"	5000	60	1.50	15	23	34.9	60.3	4 x 1/2"	0.4	0.4
3/4"	5000	60	1.50	19	30	42.9	69.9	4 x 1/2"	0.5	0.6
1"	5000	80	1.50	25	35	50.8	79.4	4 x 1/2"	0.5	0.8
1 1/2"	5000	110	1.25	38	48	73.0	98.4	4 x 1/2"	0.6	1.3
2"	5000	210	1.25	45	58	92.1	120.7	4 x 5/8"	0.9	2.0
3"	5000	400	1.25	70	90	127.0	152.4	4 x 5/8"	1.8	3.8
4"	5000	550	1.00	95	115	157.2	190.5	8 x 5/8"	2.8	5.3

Different nominal
pipe sizes on request.

L_{max} = Maximum length

d = Inner diameter of the spiral tube

d₂ = Inner diameter cylindrical

d₄ = Raised face diameter

K = Bolt circle diameter

Technical data valid for the pressure
rating Class 150.

PTFE Spiral Hoses (Class 150) with flanges and wire braid

The spiral-convoluted PTFE hose combines high flexibility with a good pressure resistance. The braiding prevents an elongation in case of compression load and serves as

protection as well as reinforcement of the PTFE Spiral Hose.



PTFE Spiral Hoses (Class 150) with flanges and wire braid

Materials Flanges:

- carbon steel
- stainless steel

Material Hoses:

- stainless steel

Lining material:

- PTFE (virgin or conductive)

Flanges:

- fix-fix
- fix-loose
- loose-loose

Other pressure rating:

- Class 300

Special features:

- earthing stud/lug
- flange stopper

Optional extras:

- final painting (flanges)

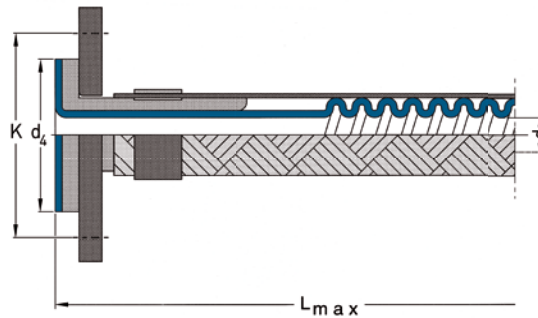

NPS	L _{max} (mm)	Min. bend radius (mm)	Max. working pressure (10 ⁵ Pa)	d (mm)	d _e (mm)	K (mm)	No. of bolts x thread (UNC)	Weights	
								Hose (ca. kg/m)	Flange (ca. kg/side)
1/2"	5000	80	10	15	34.9	60.3	4 x 1/2"	0.6	0.4
3/4"	5000	80	10	19	42.9	69.9	4 x 1/2"	0.9	0.6
1"	5000	115	10	25	50.8	79.4	4 x 1/2"	1.0	0.8
1 1/2"	5000	150	10	38	73.0	98.4	4 x 1/2"	1.3	1.3
2"	5000	200	10	45	92.1	120.7	4 x 5/8"	1.8	2.0
3"	5000	400	5	70	127.0	152.4	4 x 5/8"	3.5	3.8
4"	5000	600	5	95	157.2	190.5	8 x 5/8"	4.6	5.3

Different nominal
pipe sizes on request.

L_{max} = Maximum length

d = Inner diameter of the spiral tube

d_e = Raised face diameter

K = Bolt circle diameter

Technical data valid for the pressure
rating Class 150.

Special Parts



S

Special parts

If you did not find the piping part you need in this catalogue, please contact us. We also manufacture special forms or dimensions according to your requirements.

Simply send us your technical drawing or a sketch and we will suggest a possible solution.



Special parts

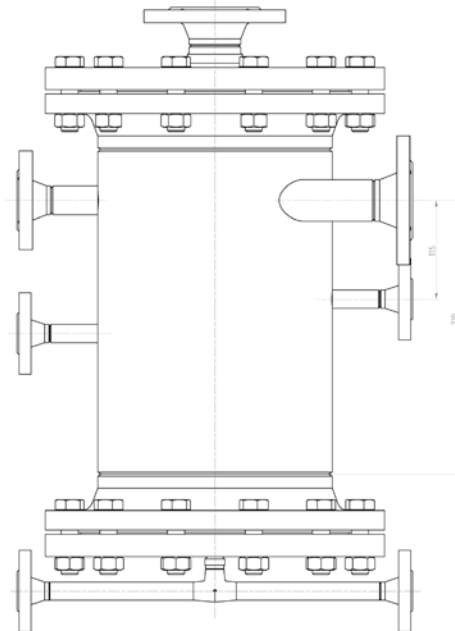
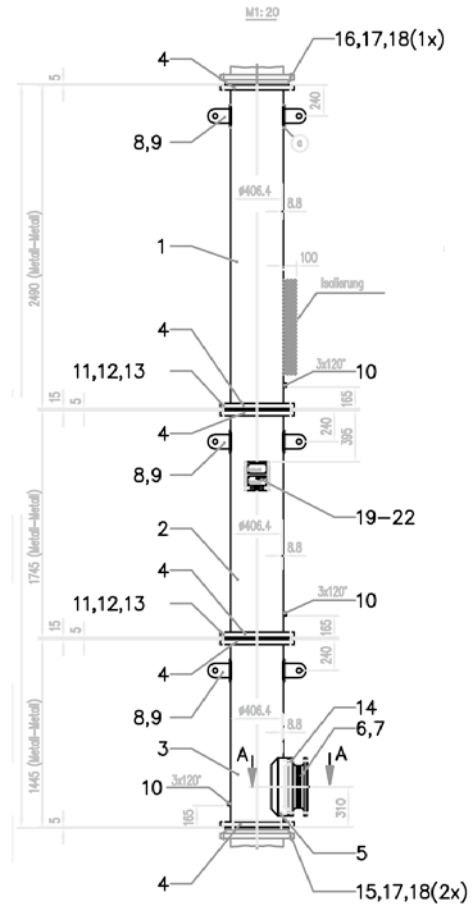

Accessories



A

Accessories

BAUM offers a comprehensive range of accessories for your piping systems, that include Safety Spray Shields and Star Washers (Contact Rings).



Accessories

Star Washer (Contact Rings)

Contact Rings ensure electric contact and conductivity between the lap-joint flange and the stub-end, even though the surface of your piping parts have a final painting. Thus secure earthing is possible with protective finishing. The Contact Rings are gripped between lap-joint flange and loose flange. The contacts of the rings

breach the painting.

The Contact Rings are manufactured from spring steel and can be applied to the following nominal pipe sizes (NPS):



NPS	
DIN	ANSI
25	1"
32	1 1/4"
40	1 1/2"
50	2"
65	2 1/2"
80	3"
100	4"

Safety Spray Shields

Many chemical plants are operated with highly-aggressive media which can cause environmental pollution or even injury as a result of personal contact. Our Safety Spray Shields offer complete security. We recommend that you consider Safety Spray Shields for flange connections, expansion joints and valves.



Technical Specifications

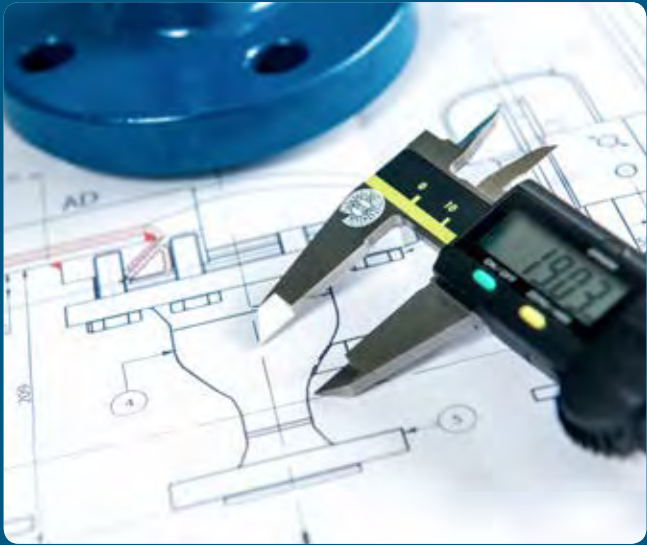

Technical Specifications

These specifications define the material, technical data, fitting instructions and quality checks for our PTFE-, PFA- or

PP-lined pipes and fittings according to ASTM F1545 and ASME B16.5.

Contents

1. Materials

- 1.1 Steel parts
- 1.2 Lining
- 1.3 External coating

2. General technical data

- 2.1 Pressure Equipment Directive (PED) 2014/68/EU
- 2.2 Steel pipe dimensions
- 2.3 Flange connections
- 2.4 Weights
- 2.5 Vent holes
- 2.6 Protective covers
- 2.7 Lining thickness
- 2.8 Operating temperatures
- 2.9 Temperature ratings
- 2.10 Operating pressures
- 2.11 Vacuum resistance
- 2.12 Tolerances

3. Quality management

- 3.1 Welding
- 3.2 Material quality certificates
BAUMCert®
- 3.3 Raw material checks
- 3.4 Visual and dimensional checks
- 3.5 Spark tests
- 3.6 Hydrostatic tests
- 3.7 Marking
- 3.8 Certificates

4. Fitting instructions

- 4.1 Protective covers
- 4.2 Gaskets
- 4.3 Tightening torques
- 4.4 Welding operations
- 4.5 Vent holes
- 4.6 Permeation und diffusion

5. Chemical resistance

- 5.1 PTFE
- 5.2 PFA
- 5.3 PP

6. Notes on development

1. Materials

1.1 Steel parts

1.1.1 All steel pipes meet:

ASTM-A 106 Gr. B

1.1.2 Flanges and stub-ends comply with:

ASTM-A 105

1.1.3 Fittings comply with:

ASTM-A 234 Gr. WPB

1.2 Lining

1.2.1 Polytetrafluoroethylene (PTFE)

The lining is made from virgin PTFE without any pigments. The minimal material characteristics according to ASTM F1545 are:

Tensile strength 20.7 N/mm²

Elongation 250%

Specific gravity 2.13 - 2.21 g/cm³

Colour white

1.2.2 Perfluoroalkoxy (PFA)

The injected material is pure PFA without any pigments. The minimal material characteristics according to ASTM F1545 are:

Tensile strength 26.2 N/mm²

Elongation 300%

Specific gravity 2.12 - 2.16 g/cm³

Colour white opaque

1.2.3 Polypropylen (PP)

All PP lining is made according to DIN 8078 Type 2. The material characteristics are:

Tensile strength 26 N/mm²

Elongation 120%

Specific gravity 0.91 g/cm³

Colour grey

1.2.4 Conductive lining

Upon request the PTFE and PFA lining can also be manufactured as conductive lining. The colour is deep black. The vertical resistance according to DIN EN 62631-3 does not exceed 108 Ohm at any place.

1.2.5 FDA conformity

Upon customer request the lining of our piping parts complies to the regulations of the Food and Drugs Administration (FDA).

1.2.6 Food Regulatory Declaration of Compliance

Upon request, we will prepare for our customers a Food Regulatory Declaration of Compliance for plastic materials intended for use in the food industry.

1.3 External Coating

1.3.1 Sandblasting

All carbon steel parts are sandblasted according to SA 2.5.

1.3.2 Paint coating

All PTFE-lined carbon steel products are painted with an epoxy-zinc-chromate primer to protect them from corrosion. Special painting on request.

2. General technical data

2.1 Pressure Equipment Directive (PED) 2014/68/EU

The piping parts are manufactured within the Pressure Equipment Directive. They fulfill all requirements of construction, manufacturing and testing. We can issue a declaration of conformity for modules A, A2, B+D, (B+C2), and G for the categories I to IV. We are also authorized to use the CE marking..

2.2 Steel pipe dimensions

The outer pipe dimensions comply with ASME B16.5.

2.3 Flange connections

Flange connections comply with ASME B16.5.

2.4 Weights of lined pipes and fittings

Please refer to the corresponding data sheets.

2.5 Vent holes

Vent holes should be kept open at all times. They have a dual function. First, they allow any permeating gas to escape. Second, they serve as leakage indicators to ensure rapid repair.

2.6 Protective covers

Flares are protected with water proof plywood covers or plastic caps. All bolts and nuts are galvanized and can easily be loosened.

2.7 Liner thickness

Various operating conditions require different liner thickness. In practice, however, thicker linings offer better safety under vacuum, better resistance against abrasion as well as lower gas permeability. The determination of a suitable lining thickness for a piping part happen in consideration of operating conditions, custom specifications or special requests. In accordance with ASTM F1545 the lining thickness must be at least 3 mm.

2. General technical data

2.8 Operating temperatures

Maximum operating temperatures are:

PTFE 230 °C

PFA 230 °C

PP 100 °C

These temperatures only apply under optimum conditions. Special demands may require a reduction in vacuum and pressure.

2.9 Temperature ratings

The interrelationship between nominal pressure and operating temperature according to DIN EN 1092-1 and operating limits of piping parts is shown below. Possibly in some cases it may deviate from the pressure-temperature-rating.

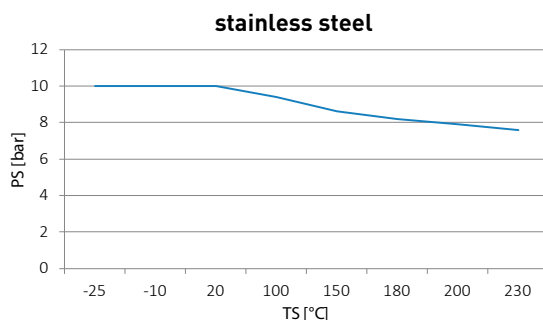
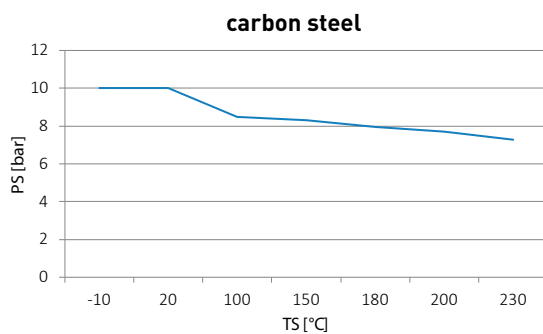

2.10 Operating pressures

The design meets the requirements of Class 150 and Class 300. Other operating pressures are available upon request in special versions.

2.11 Vacuum resistance

The vacuum resistance of the lined piping parts is determined by production technology and liner thickness. Based on your operating environment we can define the optimal liner thickness for your application. The values for vacuum resistance are given in the corresponding data sheets.

2.12 Tolerances

Tolerances of pipes and fittings are defined according to ASTM F1545 as well as ASME B16.5.

3. Quality management

3.1 Welding

Our welding processes are subject to the following criteria:

1. We are a certified manufacturer in accordance with AD 2000-Merkblatt HP 0, HP 100 R / DIN EN ISO 3834-2 / DIN EN 13480.
2. Our processes conform to AD 2000-Merkblatt HP 2 / 1 / DIN EN 13480.
3. Our operations are supervised by a certified welding expert.
4. We only employ welders with a AD 2000-Merkblatt HP 3 / DIN EN 13480 certificate.

3.2 Material quality certificates BAUMCert®

All steel pipes, flanges, stub ends and welded steel fittings are certified according to DIN EN 10204 - 3.1.

3.3 Raw material checks

Lining materials are only procured with material quality certificates WAZ 2.2 from manufacturers certified according to ISO 9001.

3.4 Visual and dimensional checks

In addition, our own laboratory continually checks and records the physical data of semifinished products from the production line. The dimensions of all pipes and fittings are checked visually.

3.5 Spark tests

All non-conductive lined pipes and fittings subjected a 25kV or 30kV spark test to make sure the lining is not porous.

3.6 Hydrostatic tests

The hydrostatic test is carried out at the 1.43-times of the nominal pressure.

3.7 Marking

In accordance with ASTM F1545, every pipe and fitting is marked on the circumference of the flange as follows:

- Manufacturer's name
- Production lot
- Lining material
- Date of production
- CE marking (if applicable)

Additional markings – for example material no. etc. – are available upon customer request.

3. Quality management

3.8 Certificates



4. Fitting instructions

4.1 Protective covers

Protective covers must only be removed immediately before fitting.

4.2 Gaskets

Flared surfaces of identical materials (PTFE/PFA) do not require gaskets. Gaskets are only needed for connections frequently undone or for connections to other materials such as metal, glass, enamel, etc.

4.3 Tightening torques (for pressure rating Class 150)

When using smooth-running and greased bolts and nuts we recommend the tightening torques in the table below:

NPS	Bolts	Tightening torques (Nm)
1/2"	4 x 1/2"	6
3/4"	4 x 1/2"	10
1"	4 x 1/2"	14
1 1/2"	4 x 1/2"	28
2"	4 x 5/8"	53
2 1/2"	4 x 5/8"	66
3"	4 x 5/8"	94
4"	8 x 5/8"	67
5"	8 x 3/4"	101
6"	8 x 3/4"	128
8"	8 x 3/4"	178
10"	12 x 7/8"	175
12"	12 x 7/8"	228
14"	12 x 1"	285
16"	16 x 1"	265
18"	16 x 1 1/8"	389
20"	20 x 1 1/8"	344

The torque wrench should be used in a cross manner. Tightening torques for other pressure rates available upon request. Details for assembly and operating instructions can be found in our data sheet FB 8.3.5.

4.4 Welding operations

Lined pipes and fittings may not be welded, as the high temperature will destroy the synthetic material.

4.5 Vent holes

Vent holes should at all times be kept open. Not clog them with paint or insulating material.

4.6 Permeation and diffusion

The term "permeation" defines the particle transport of operating medium in a piping through the lining. Permeation is caused by two physical incidents. First, the diffusion of the operating medium through the spaces between the molecules of the plastic. Second, the solubility of the operating medium in the polymer (absorption). Diffusion can be decreased by the choice of suitable types of PTFE, by increasing the liner thickness and by using higher levels of crystallinity. However, this increases the risk of cracks caused by strain. To ensure optimal product safety all aspects have to be taken into consideration. Absorption defines the diffusion of operating medium into the liner.

Cyclical stress due to temperature or pressure leads to elongation mechanisms which cause aggregations of operating medium and even blisters. Isolation of those piping parts can avoid or reduce those effects considerably.

5. Chemical resistance

5.1 PTFE

PTFE has a universal chemical resistance against almost all chemicals and solvents within its continuous operating temperature – with the exception of molten alkalis, elementary fluorine and certain halogenes.

5.2 PFA

Properties of PFA are comparable to PTFE (see 5.1).

5.3 PP

Please refer to the information specified by the manufacturer.

6. Notes on product development

We reserve the right to vary between the lining materials PTFE and PFA for manufacturing reasons.

This product catalog is based on the experience we have gained up to now, it is intended to provide the user with advice.

All information is to the best of our knowledge and believed to be correct and given without responsibility. Illustrations of products are shown exemplary and do not necessarily represent the actual shape.

Technical changes resulting from the further development of our products may occur without giving prior notice.

Edition 2024